

KIT NO. 3045

1/8th SCALE RADIO CONTROLLED OFF-ROAD RACE CAR
CIRCUIT 20 EXTRA

RACING BAJA

DIFFERENTIAL GEAR BUILT-IN, ULTRALIGHT WITH STRONG CHASSIS, HI-SPEED JUMP AND RUNNING,
PERFECT MECHANICAL DESIGN FOR OFF-ROAD RACE, .19-.21 ENGINE 2 CHANNEL RADIO



Thank you very much for the purchase of R/C Car "CIRCUIT 20 EXTRA RACING BAJA" to be able to properly assemble your "CIRCUIT 20 EXTRA RACING BAJA" and get maximum performance, we would like you accordance to this instruction sheet.

By reading this instruction to the end thoroughly before assembling and keeping in mind the overall construction, it will enable you to work smoothly. If the engine you will be using is still brand new, by breaking in the engine according to instruction sheet included in with the engine, it will be possible to maintain high performance and longer engine life.

ARTICLES REQUIRED OTHER THAN THE KIT

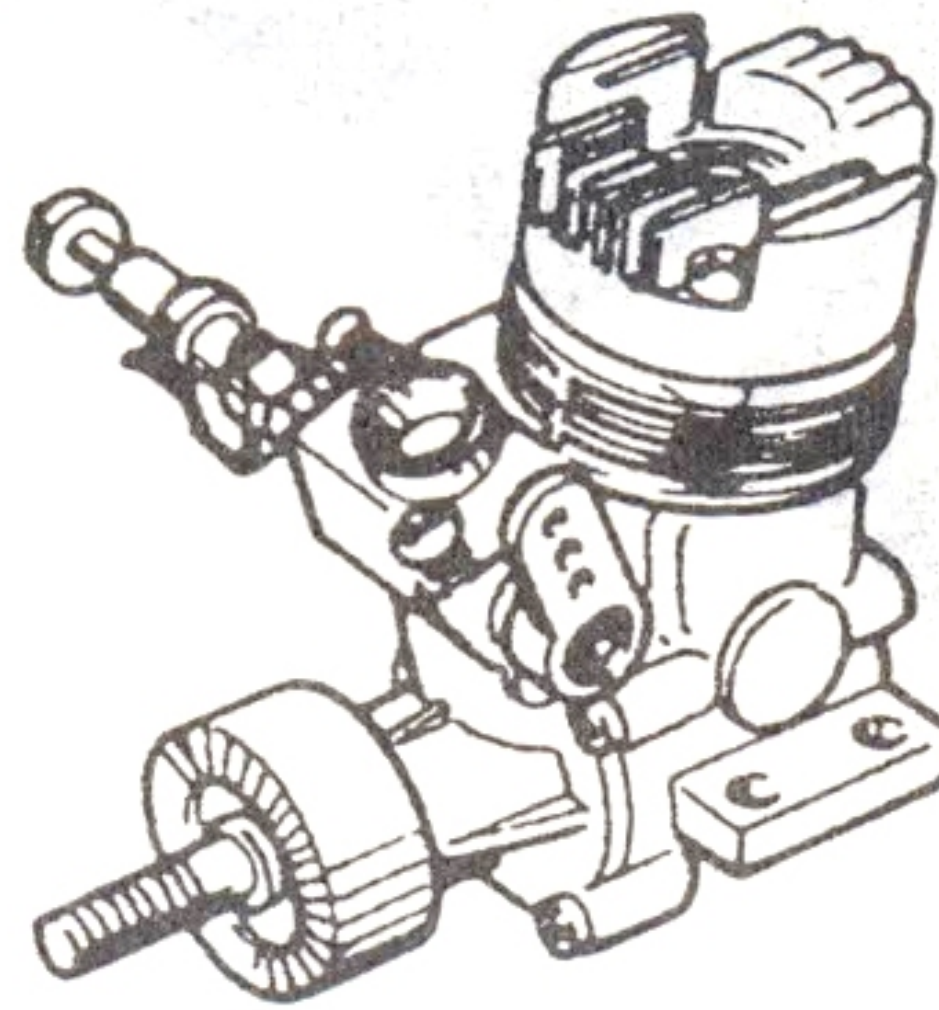
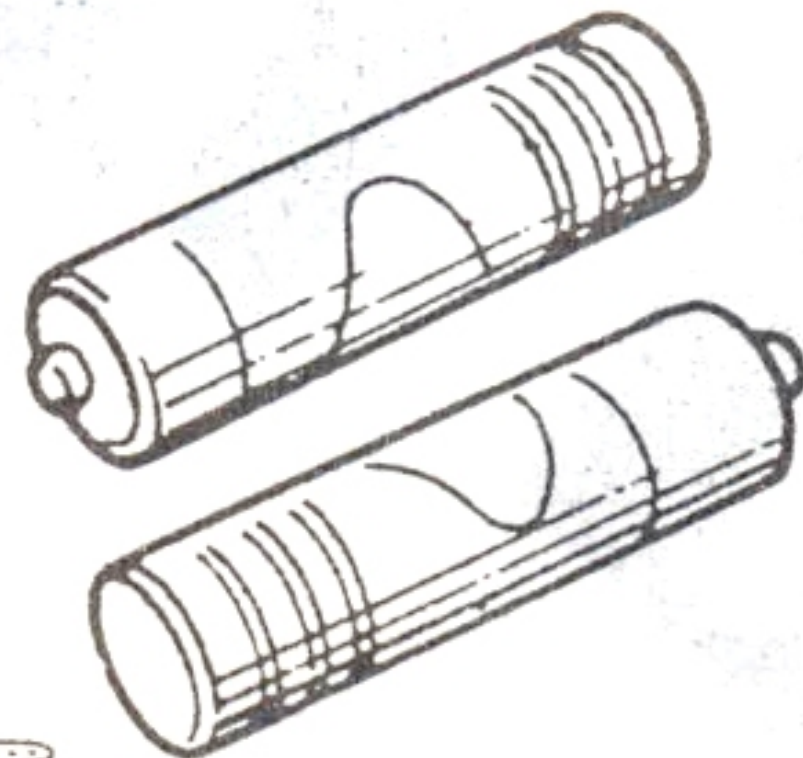
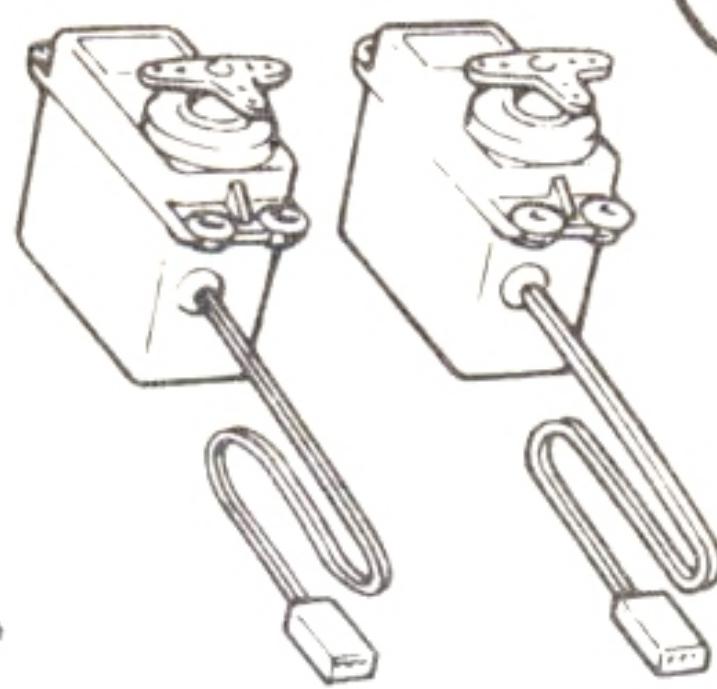
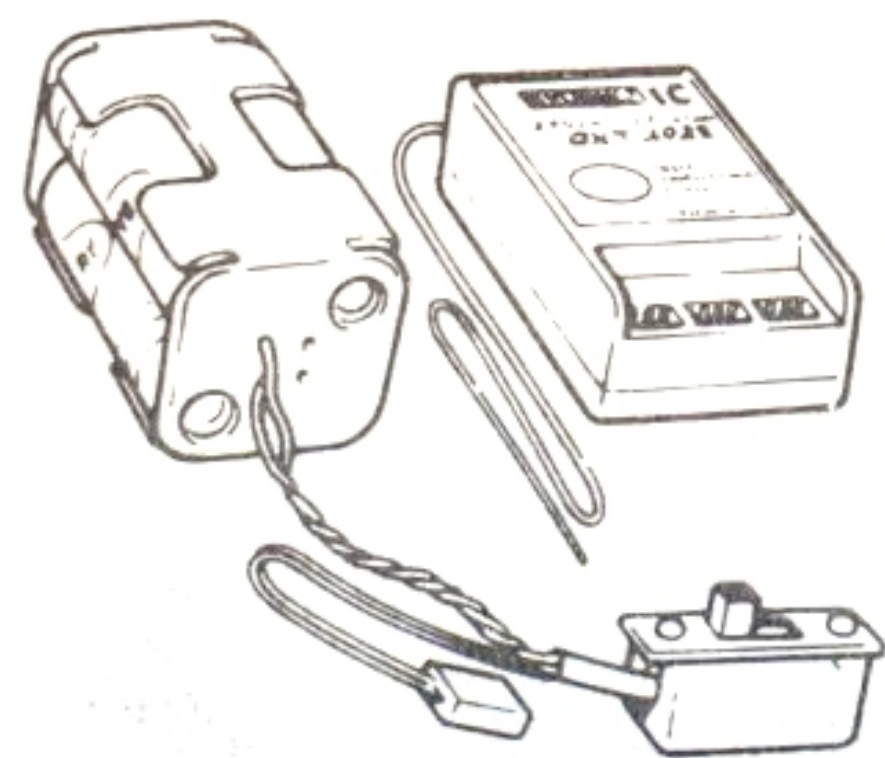
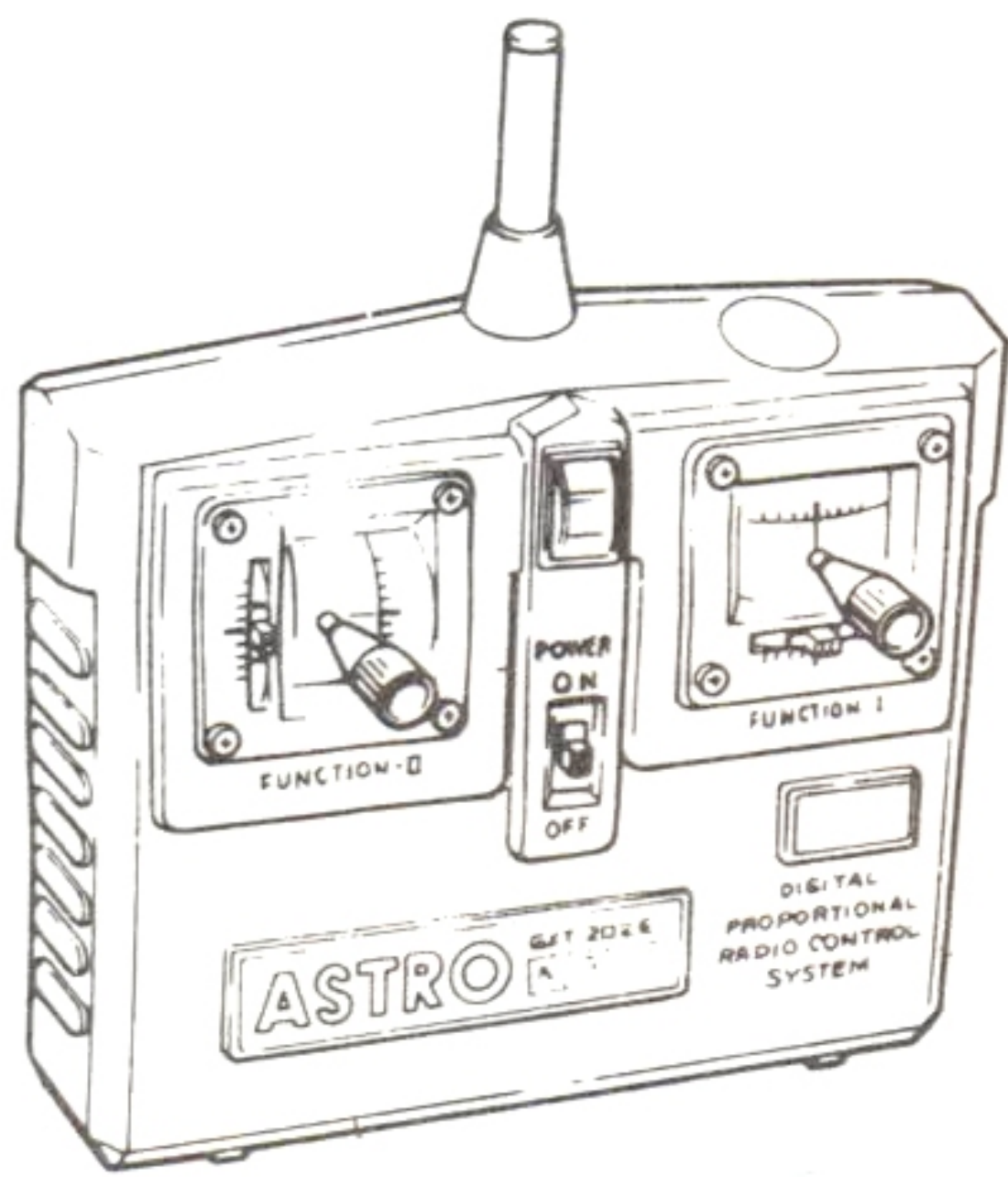

Transmitter UM-3 x 6 - 8 pcs.
Receiver UM-3 x 4 pcs.
Battery for Radio

Note:
This kit being designed for Enya .19, 21X and OS-21 engine. option parts and/or minor modification necessary to use other engine.

Glow Plug
(1.5V White Gold will be the best)



OS-21FSR or Enya 19, 21X engine

TOOLS REQUIRED FOR ASSEMBLING

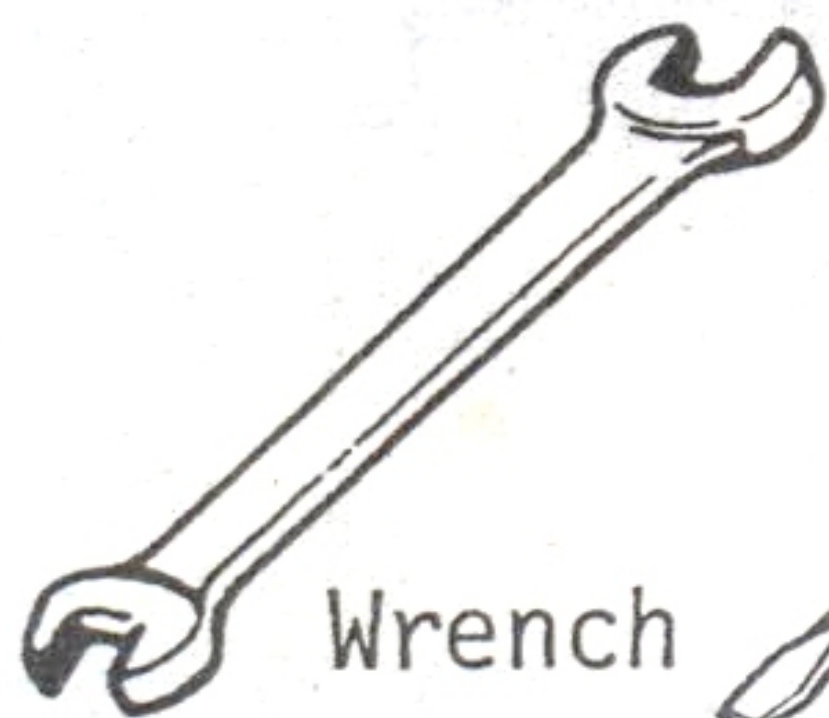

Wrench

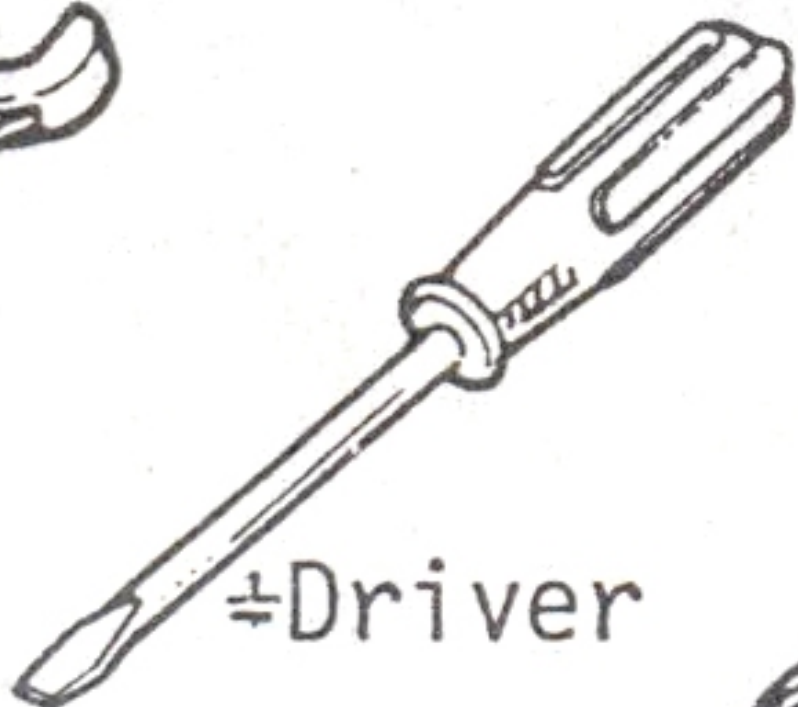

+Driver

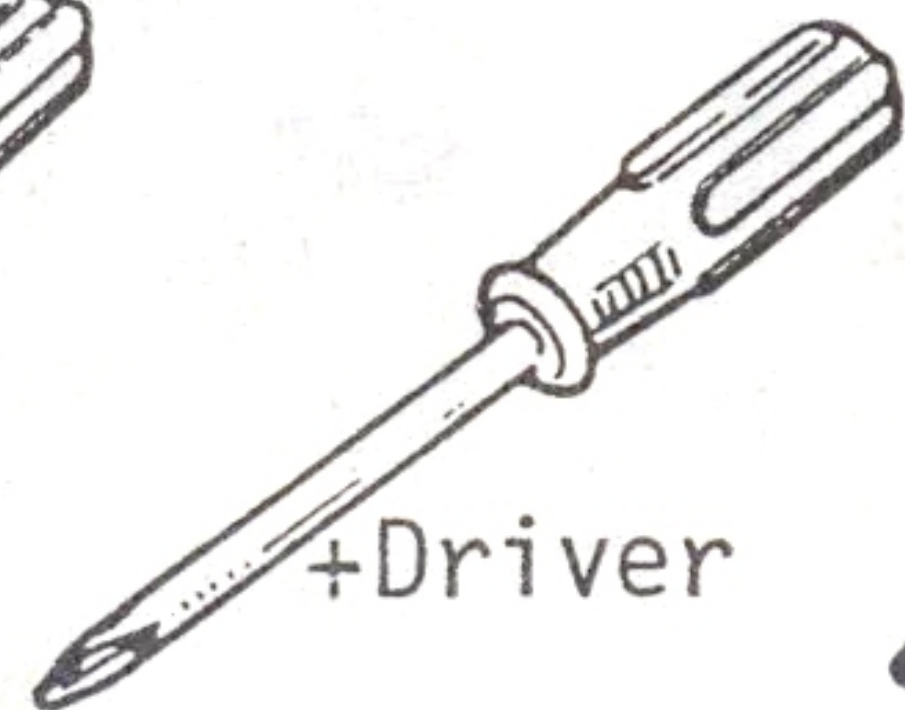

+Driver



Radio Plier

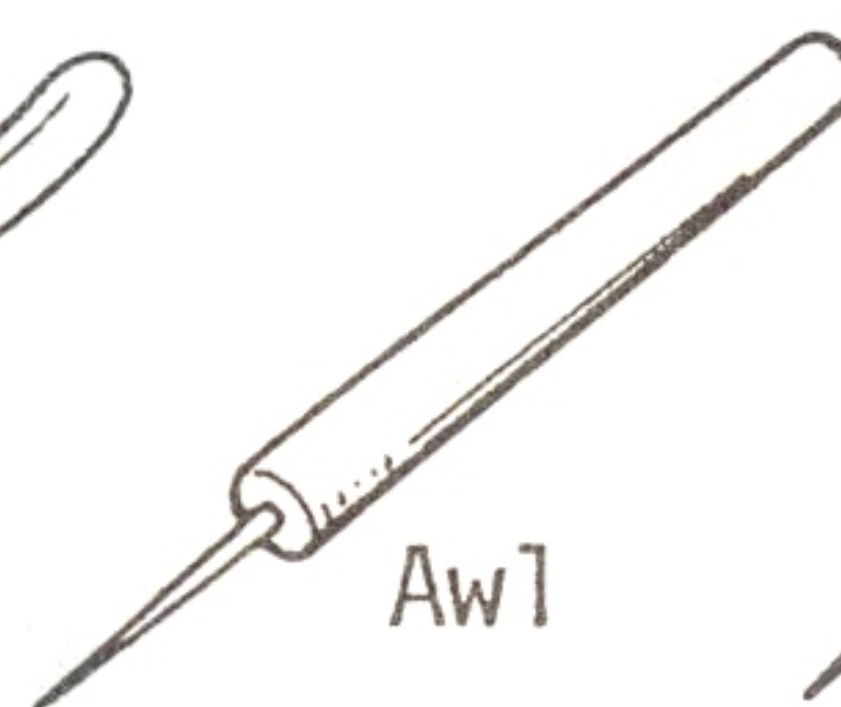

Awl

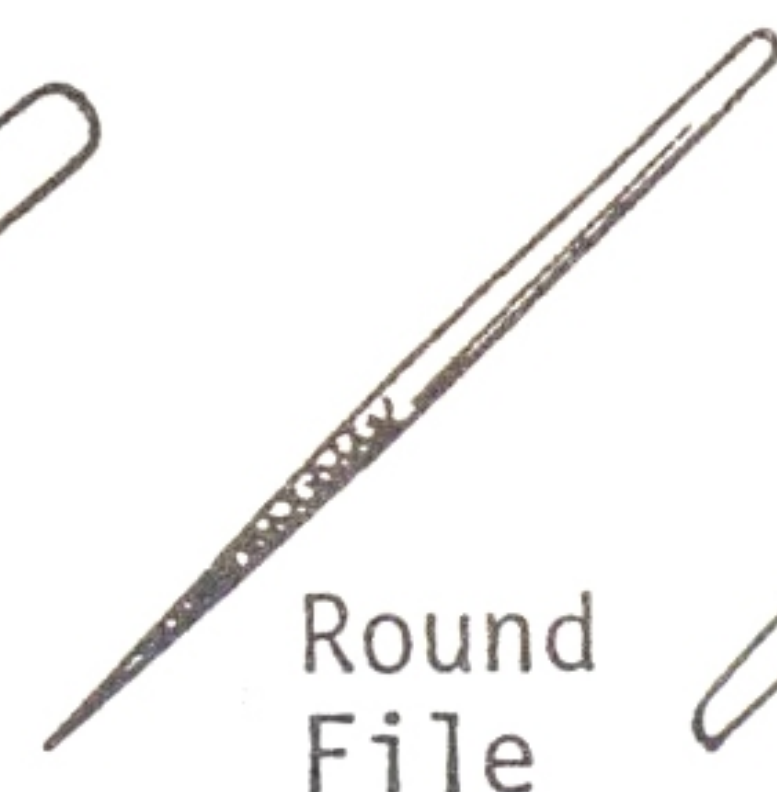

Round File



Scissors

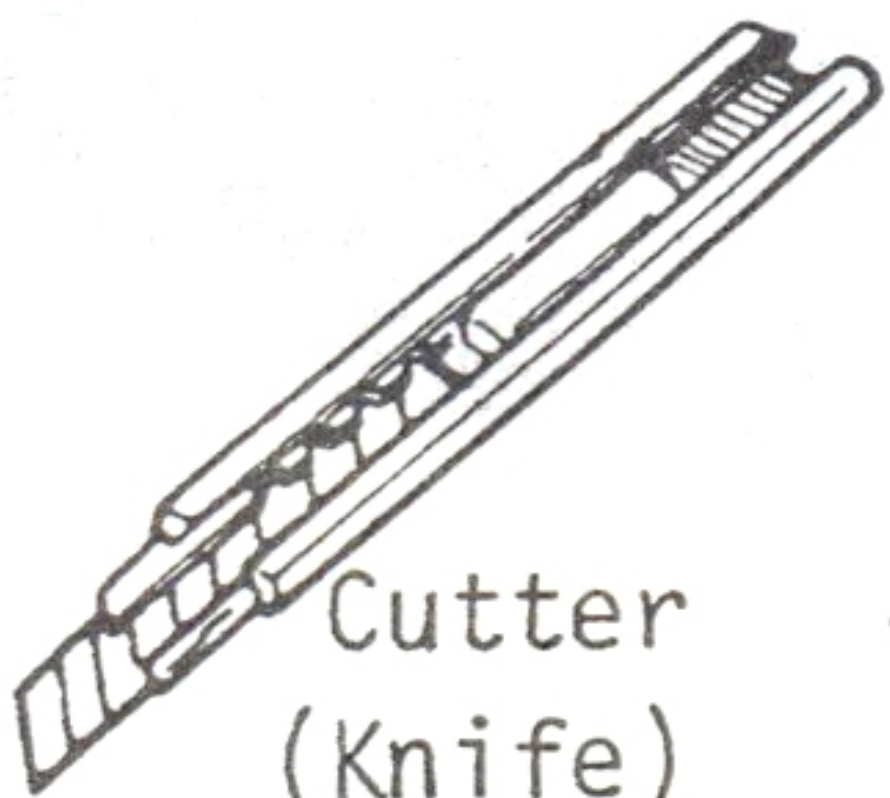

Cutter (Knife)



Sand Paper

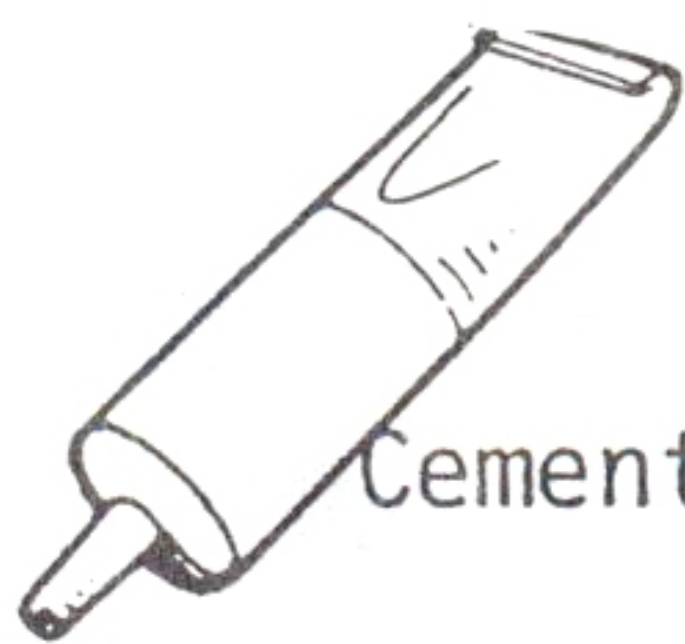

Cement



Polyca Color



Brush



Masking Tape

ARTICLES REQUIRED FOR RUNNING

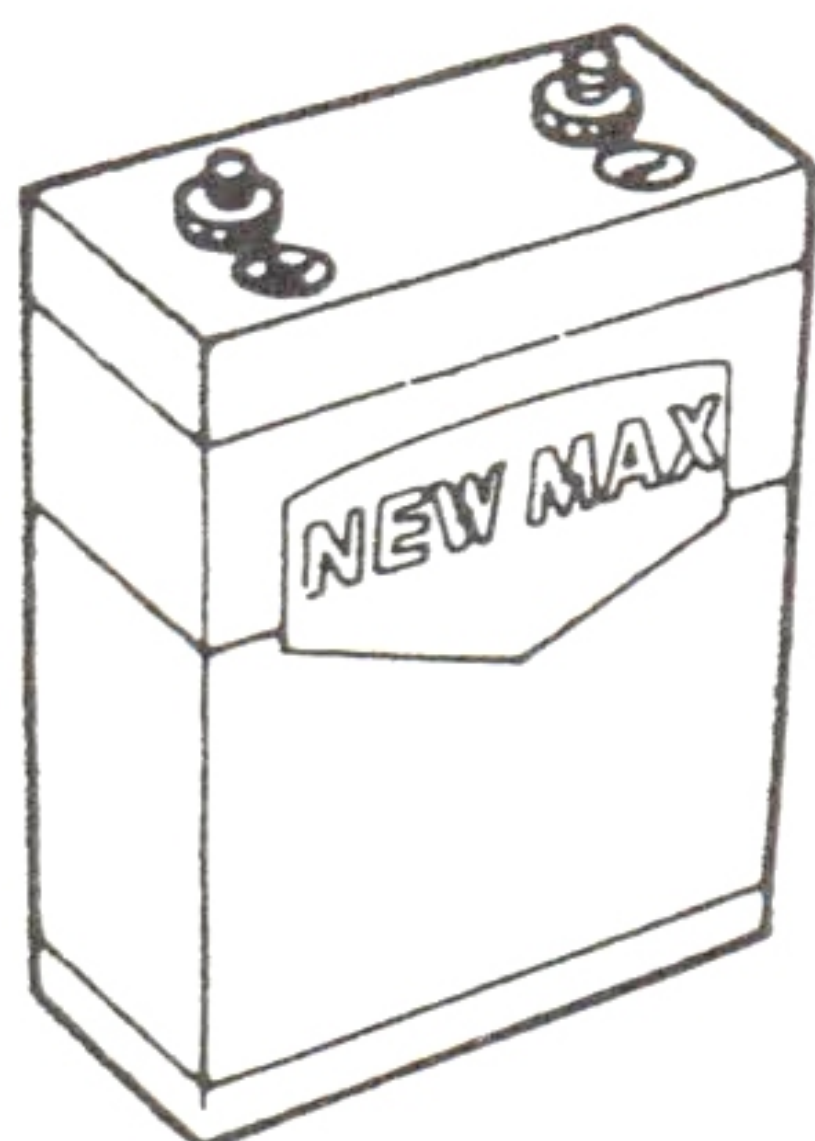

Battery Plug Heating

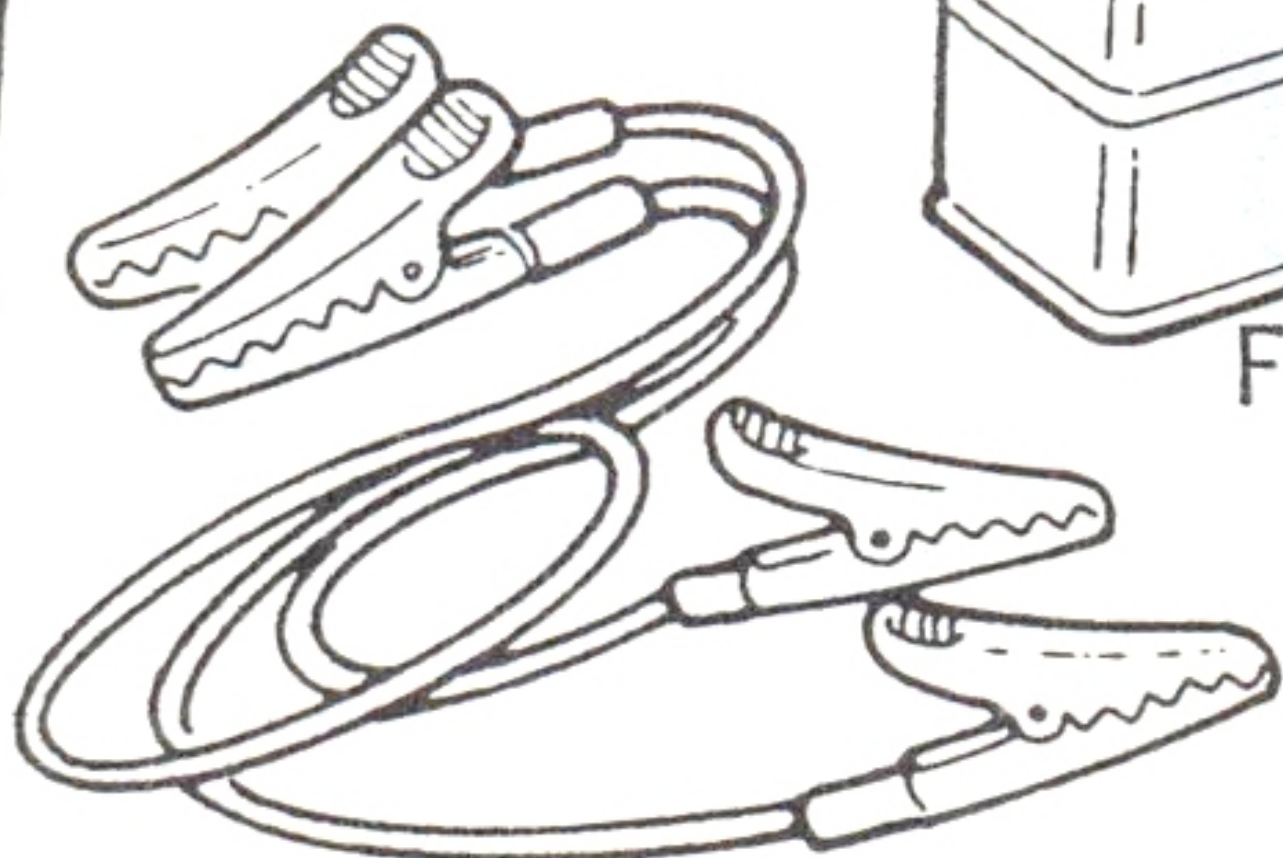

Booster Cord

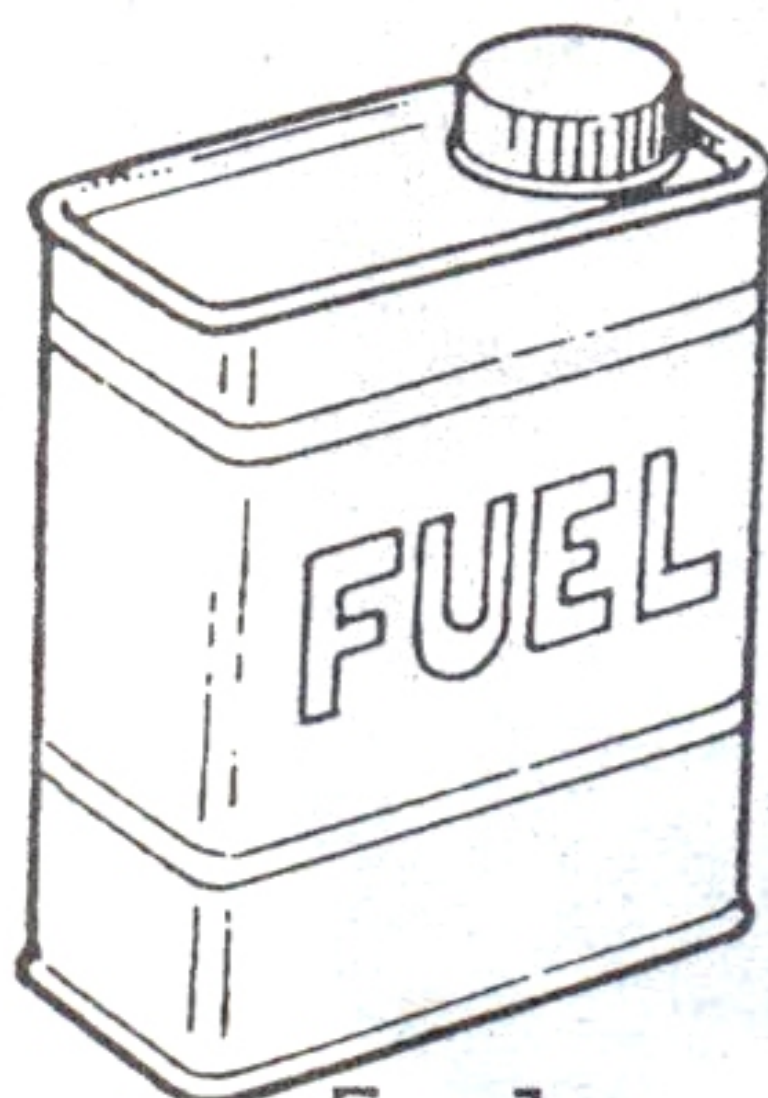

Fuel



Fuel Tank

Electric Starter

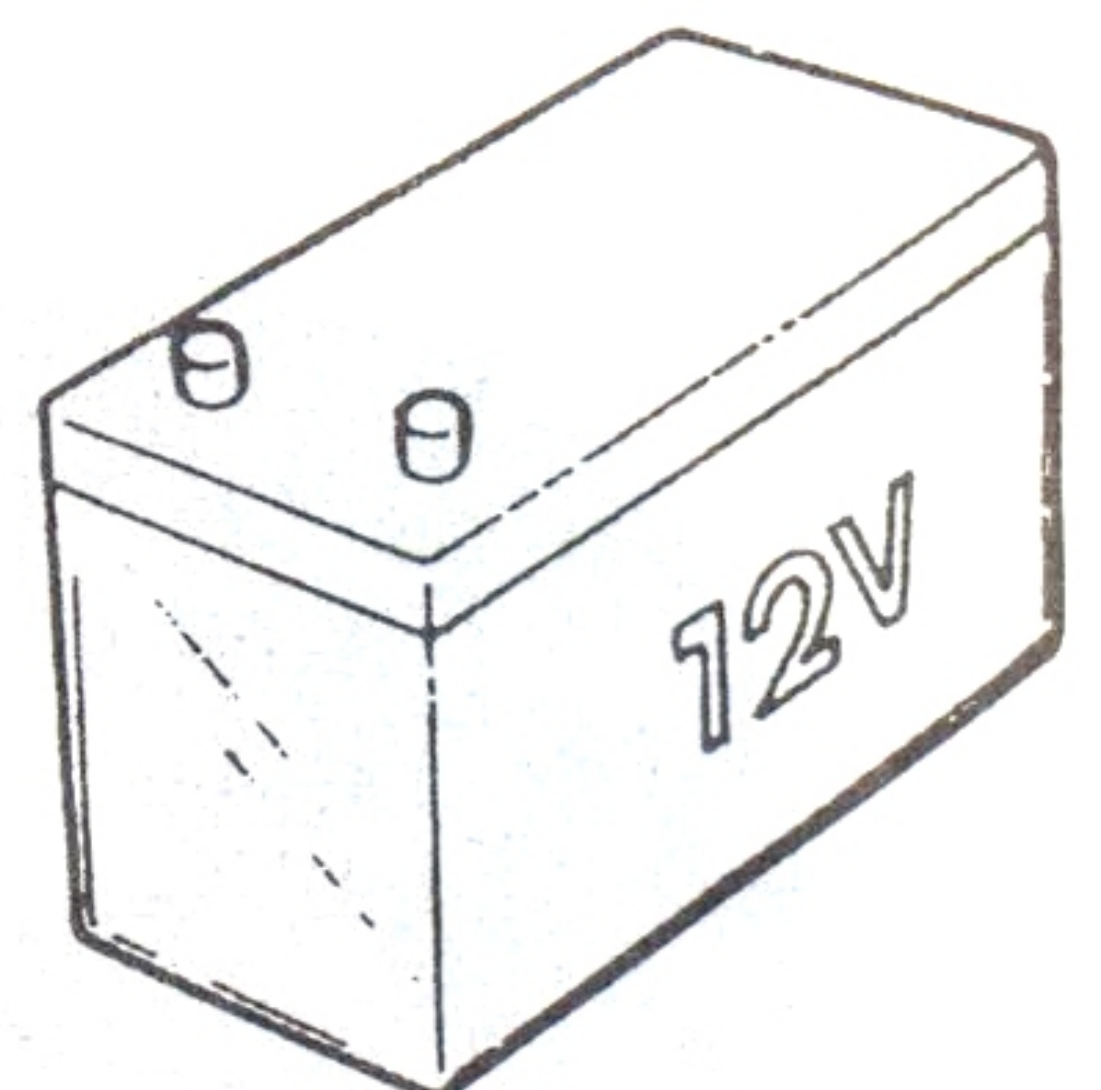
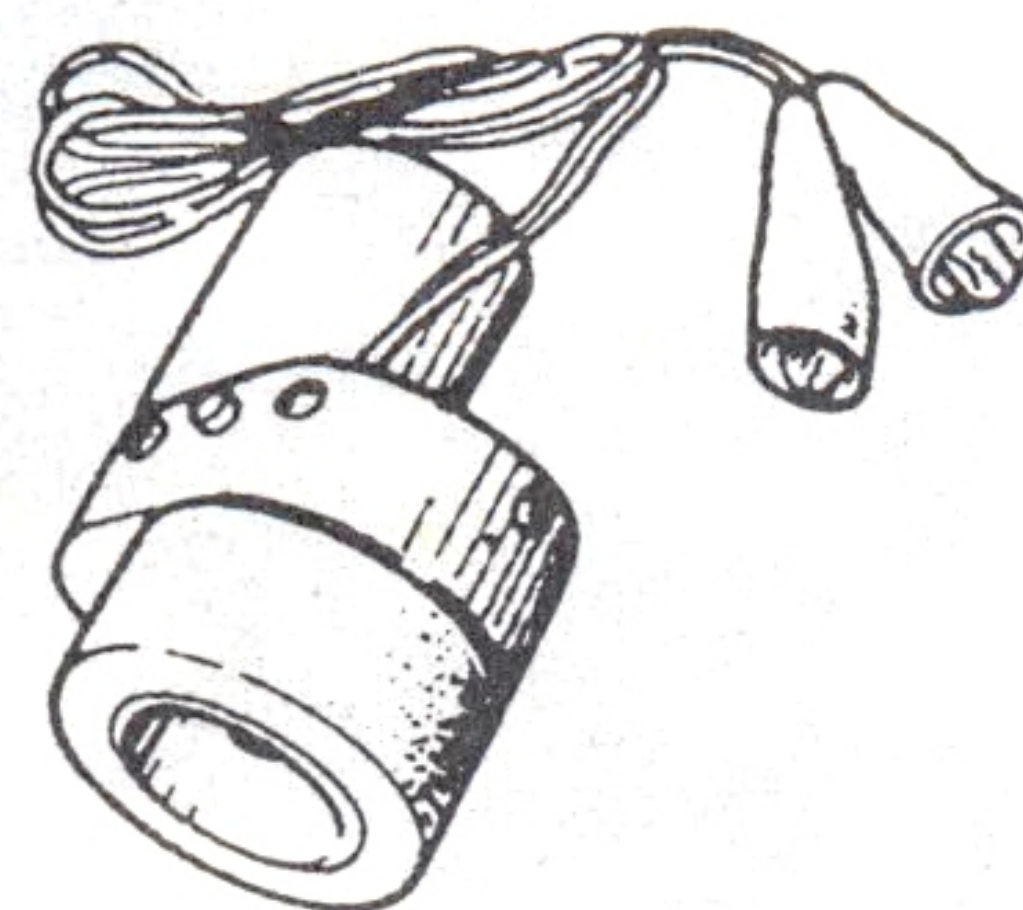

Starter Battery

Small parts in step 1 - 4 are included in front end section parts #1 bag.

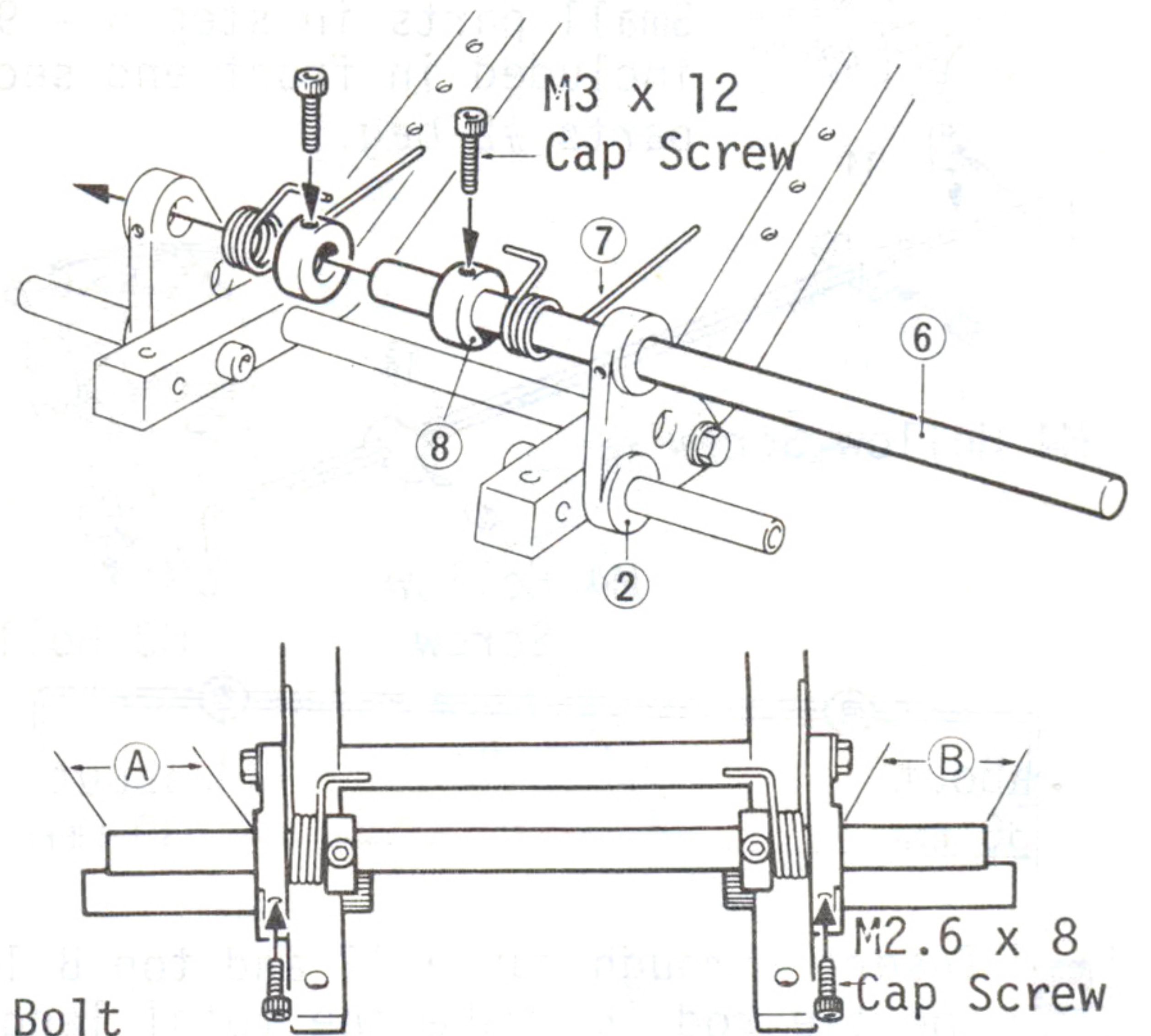
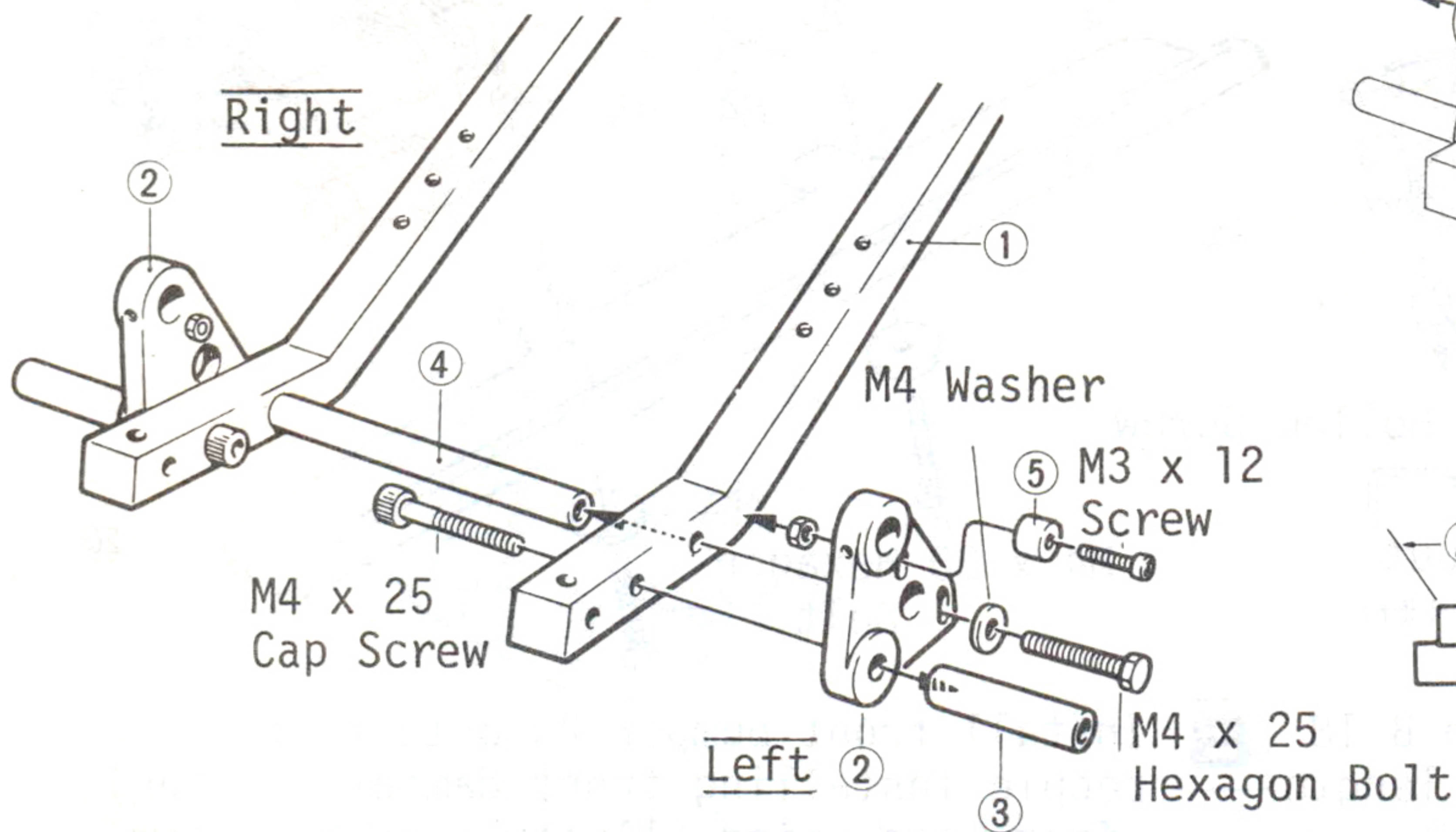

1 Fix the arm holder 2 and other parts on the main frame 1. The installing hole for the suspension stopper 5 is made to be oval for the adjustment of the body height. When the stopper is set upward, the altitude of the car will be low; and downward it will be high.

2 In order not to make a mistake on the right and left front spring, arm axle B 6 is set into place with M2.6 cap screw onto arm holder 2 as illustrated. But it is stabilized making the length of A . B in the same length as shown in illustration below.

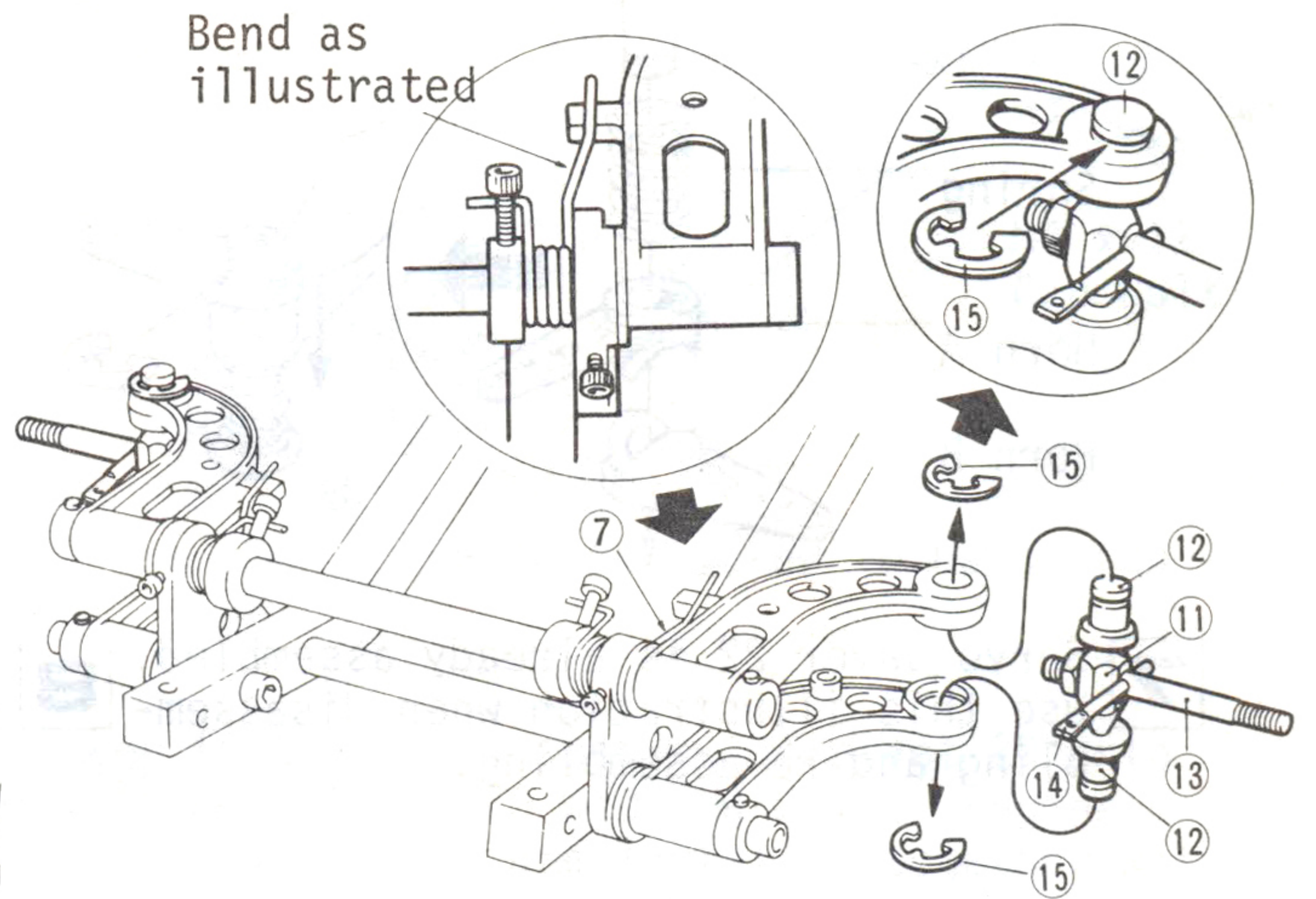
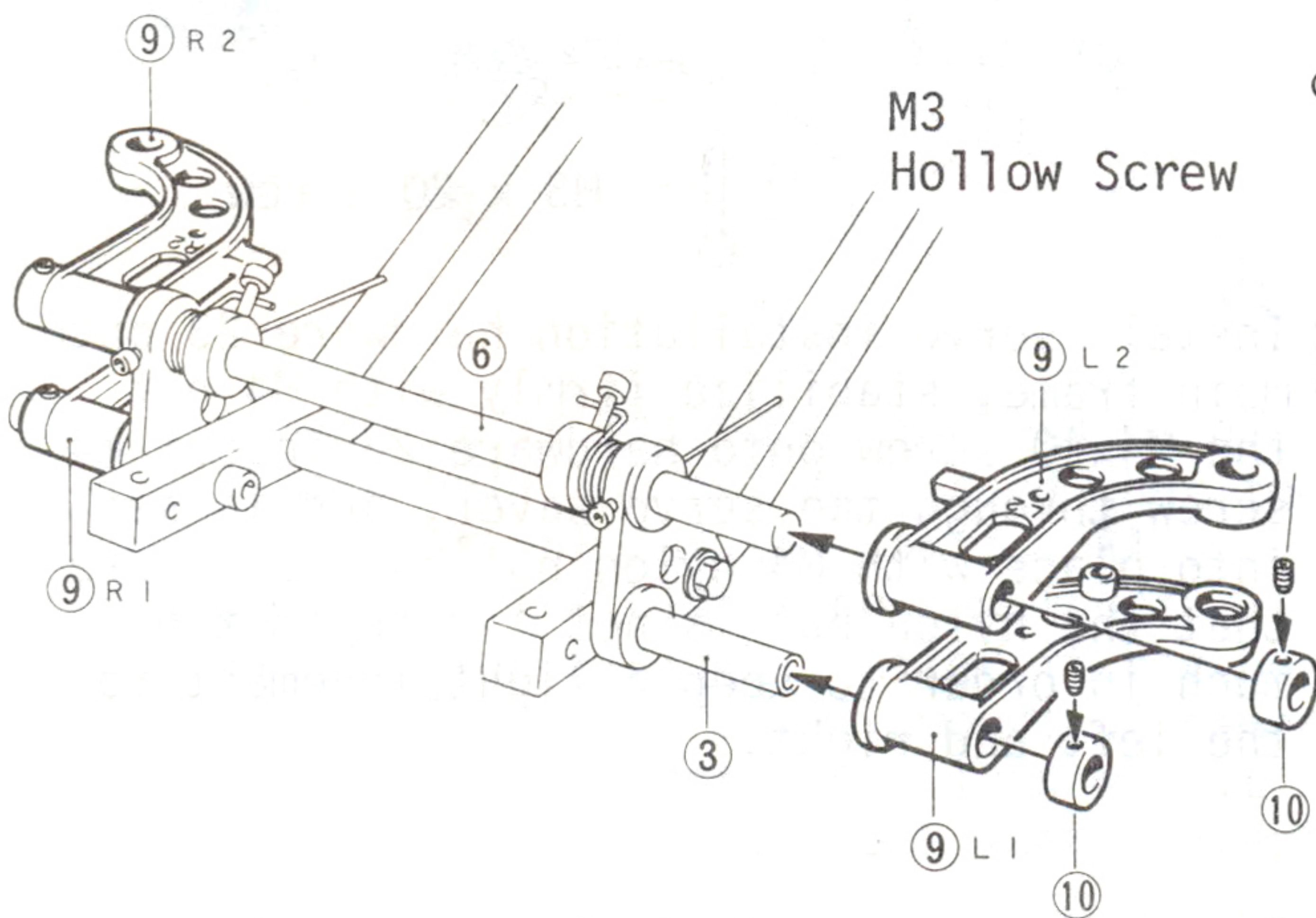

3 As L1, L2, R1, R2 are stamped on the each front suspension arm 9, using illustration as reference, insert arm axle A 3 and B 6 and then is installed with suspension side Stopper 10 but when doing so, set it so the there will be no excess play to the right and left on the suspension arm and have it so it will move up and down freely.

4 Insert into front suspension arm the already assembled parts (key nos. 11 12 13 14 and then hold place with "E" right 15. Next, set the front spring 7 into place as illustrated.

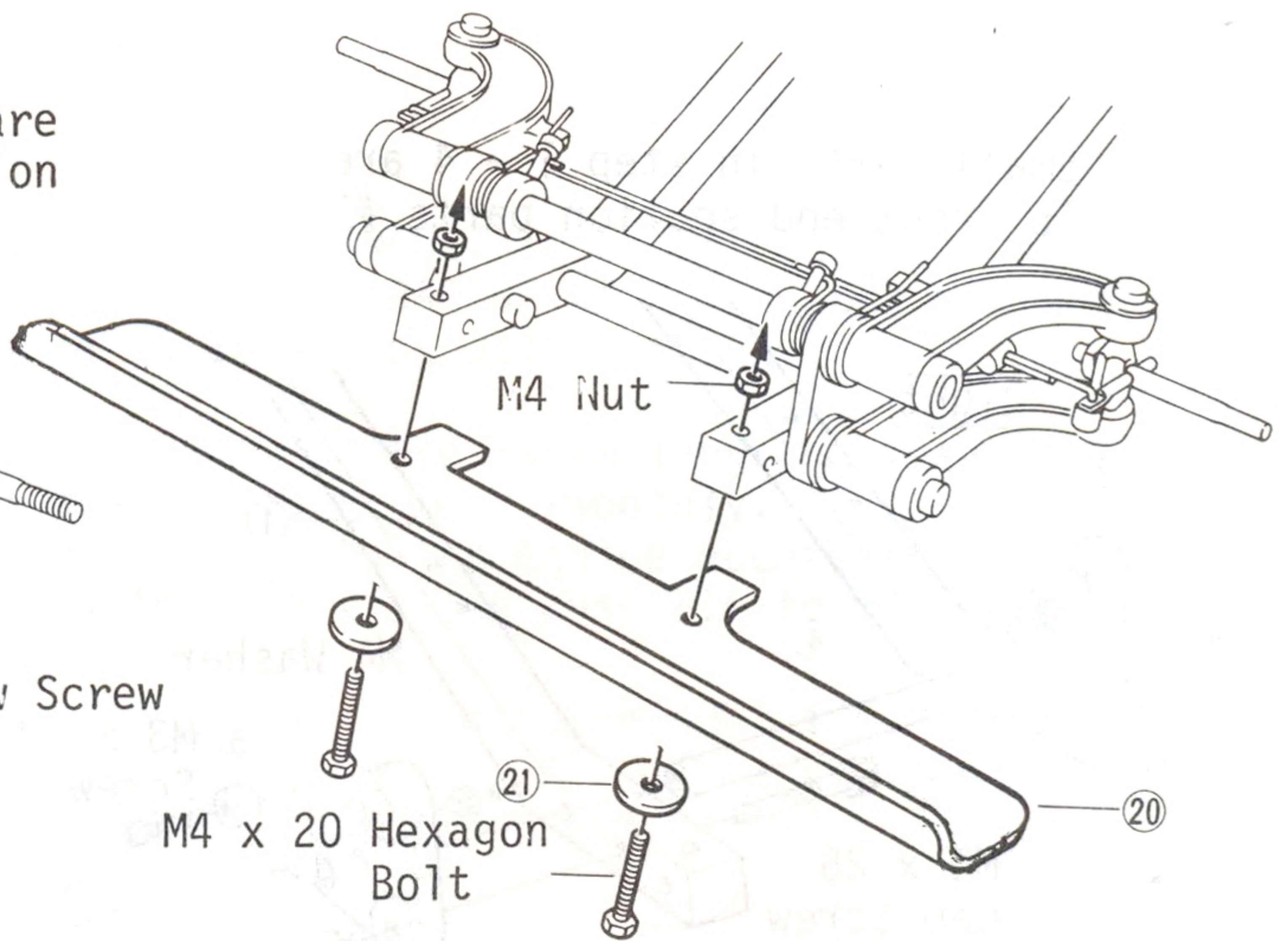
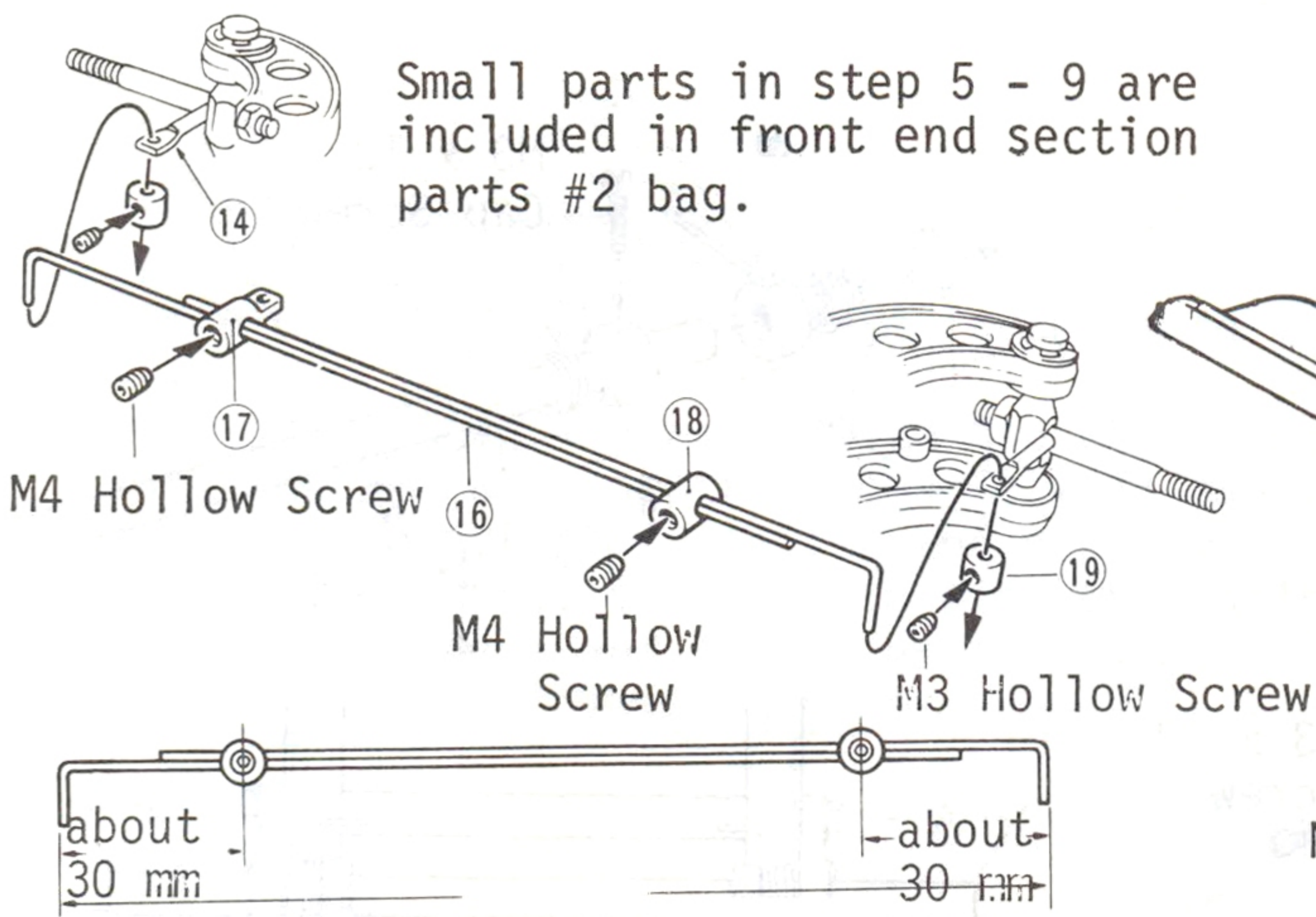

5 Insert through tap a 17 and top B 18 the tie rod 16, make the total length of the tie rod about 210 mm long, position the tap approximately 30 mm from the end, install the tap with M4 hollow screw and stabilize into place using tie rod stopper 19.

6 Install front bumper 20 onto frame. For people installing front damper (option), after completing illustration 6, assemble by using illustration [51] on page 16 as reference.

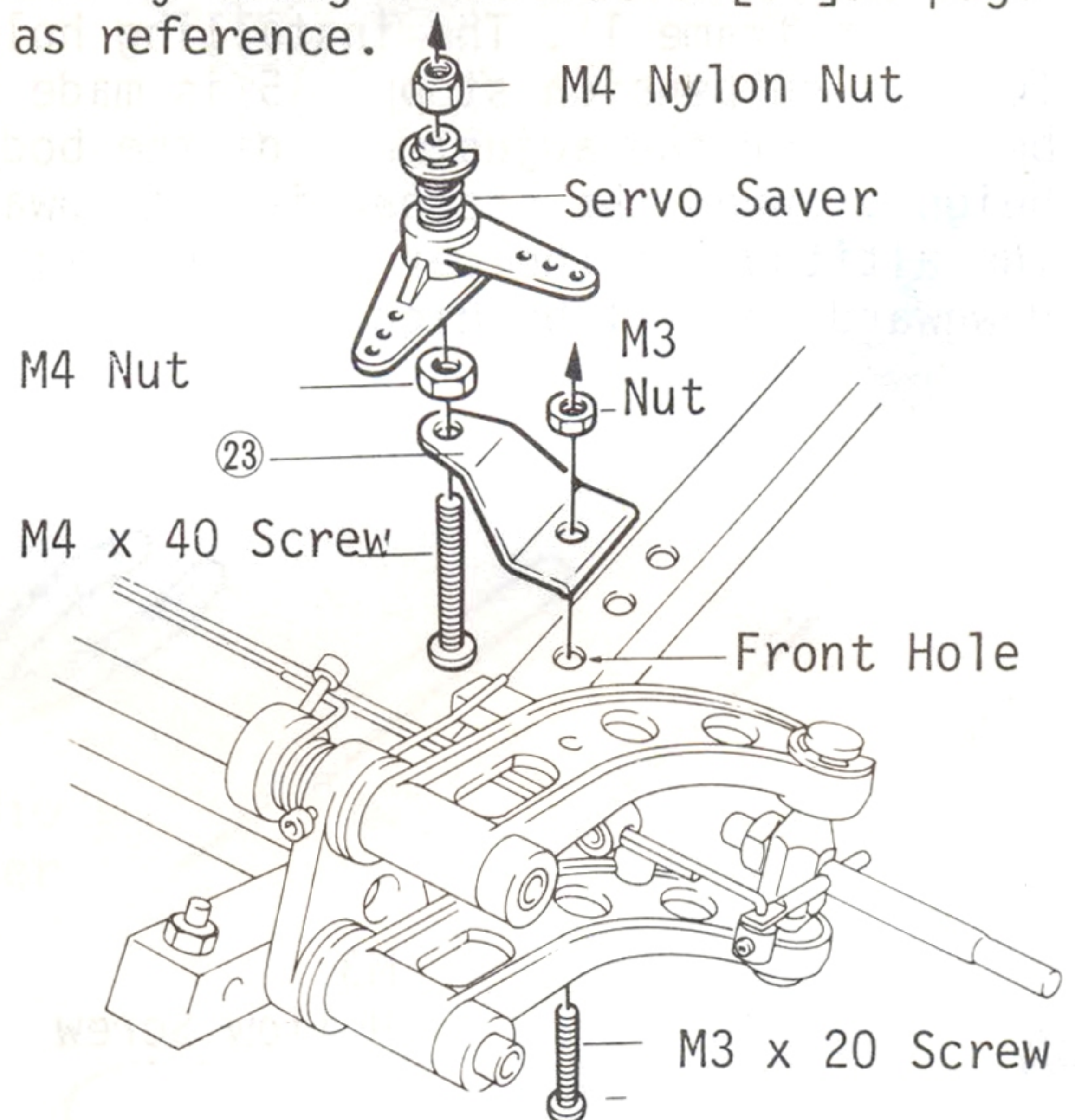
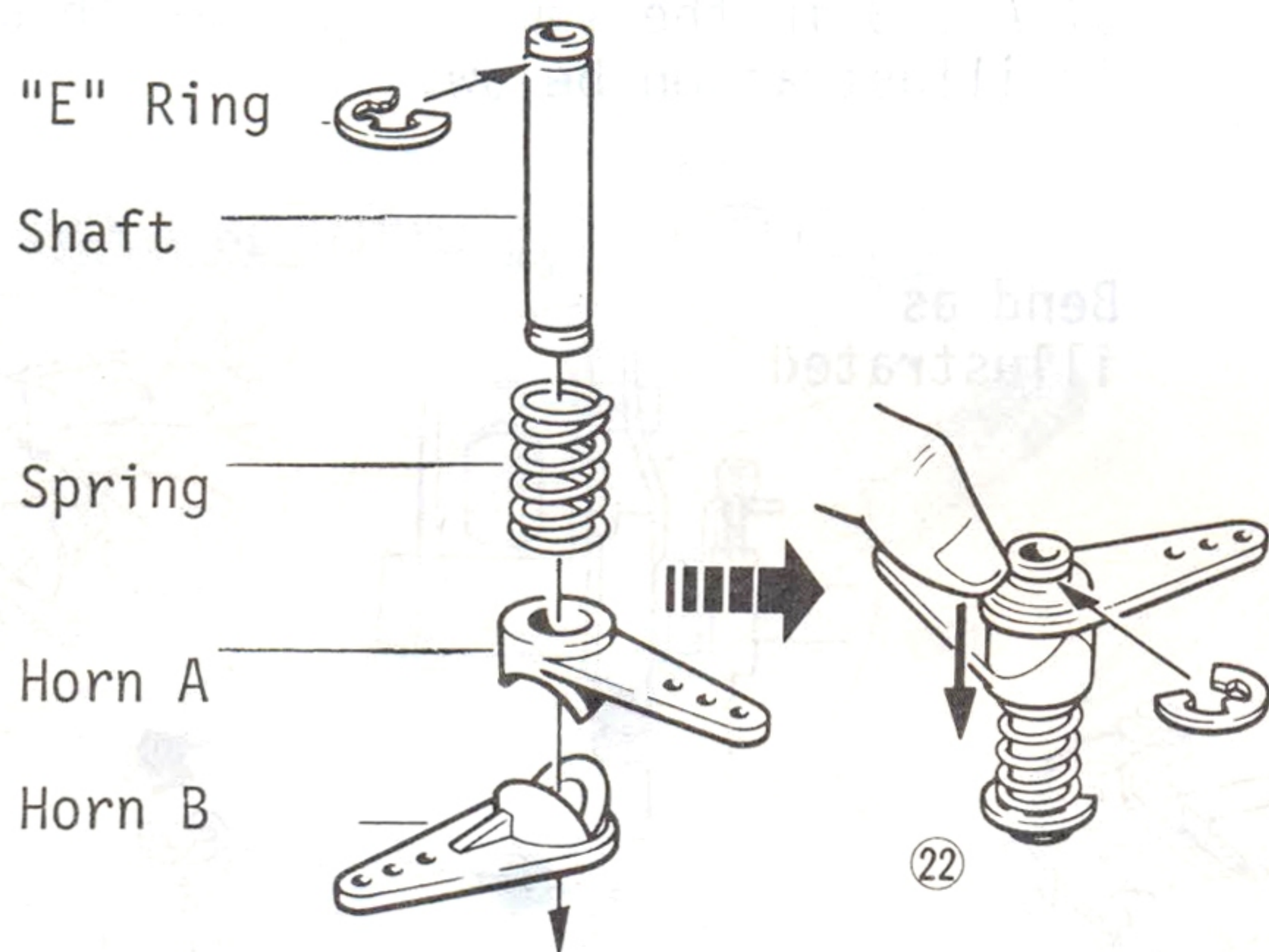

7 Servo saver 22 is already assembled. Use this illustration when disassembling and re-assembling.

8 Install servo installation hardware 23 onto main frame, stabilize firmly with M4 nut the M4x40 screw onto hardware 23 insert M4 screw through the servo saver, and is set into place with M4 nylon nut but make sure that the nylon nut is not tightened too much in order to keep a light movement to the left and right.

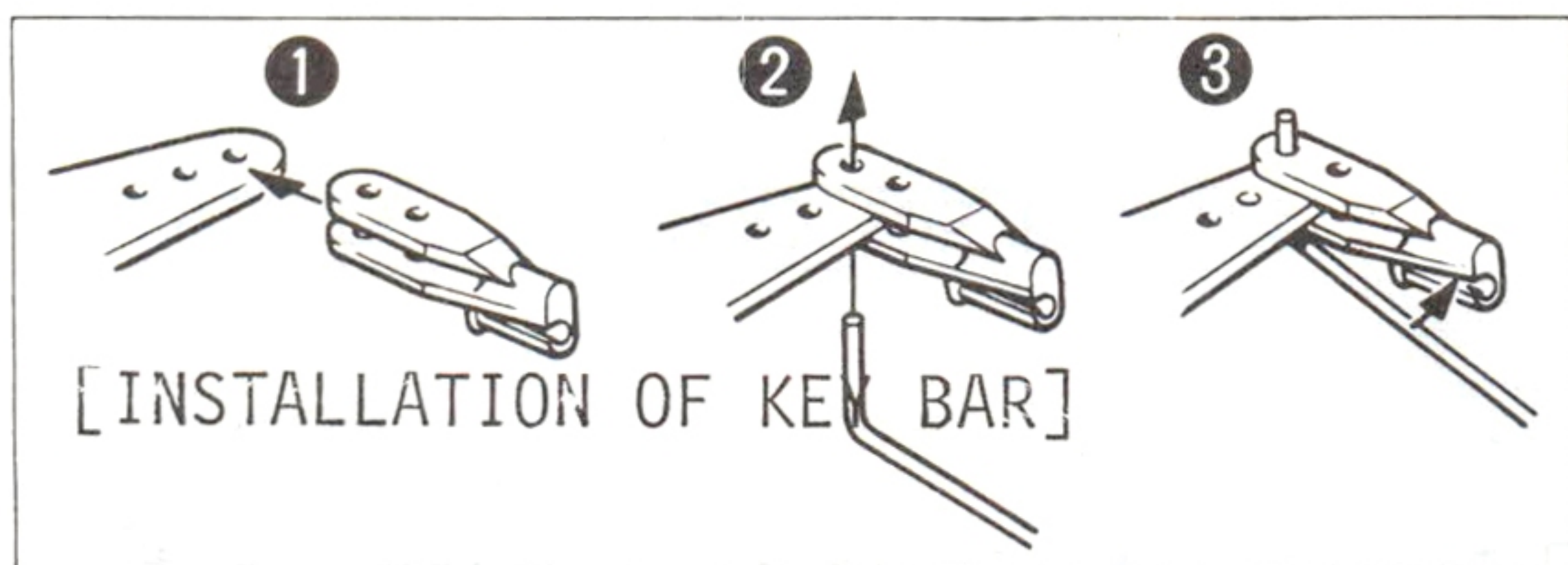

9 Insert Steering rod 24 through tap 17 and install the other end to the servo saver using keeper 25.

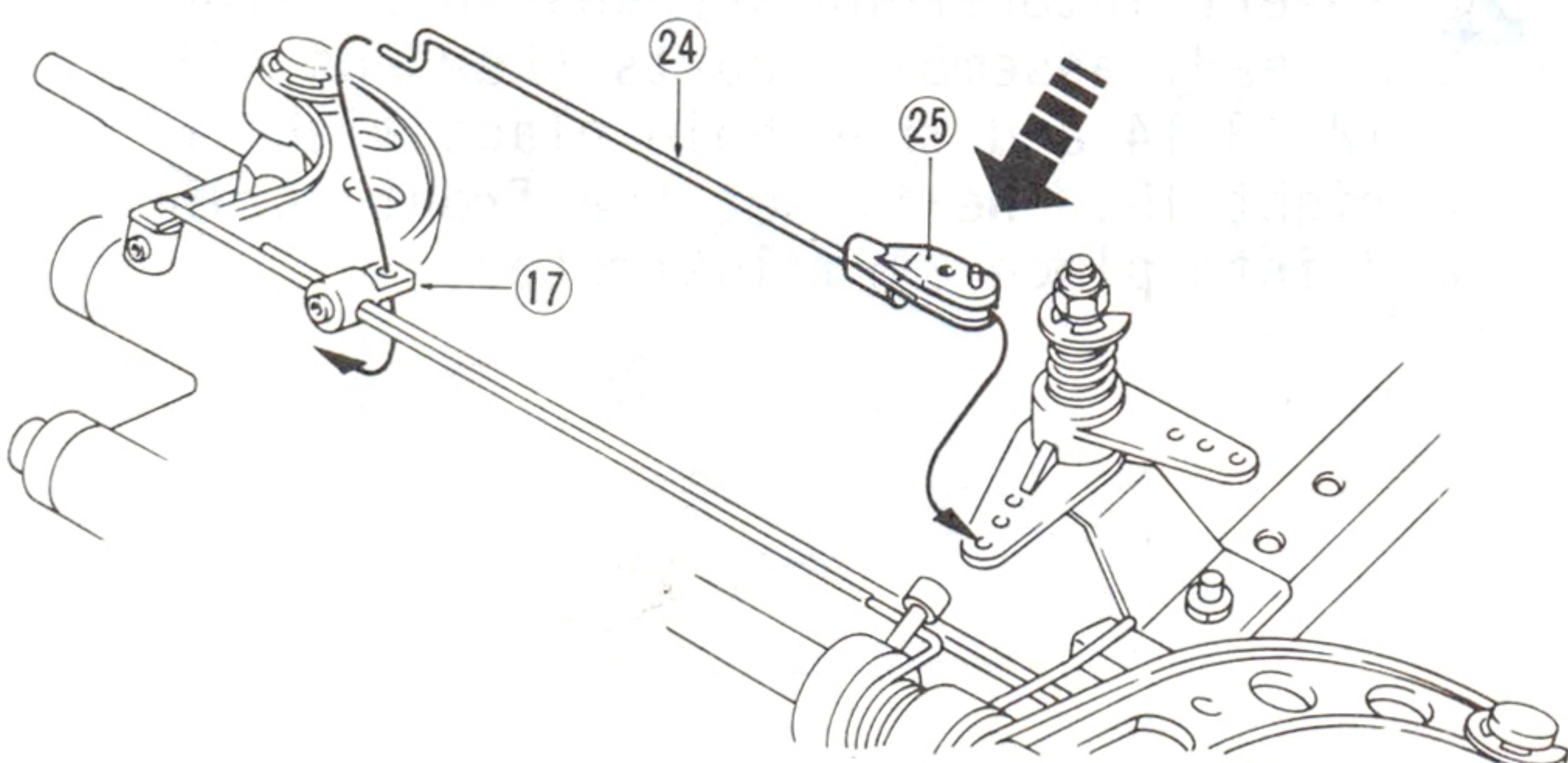

Small parts in step 10 - 17 are included in rear parts section parts #1 bag.

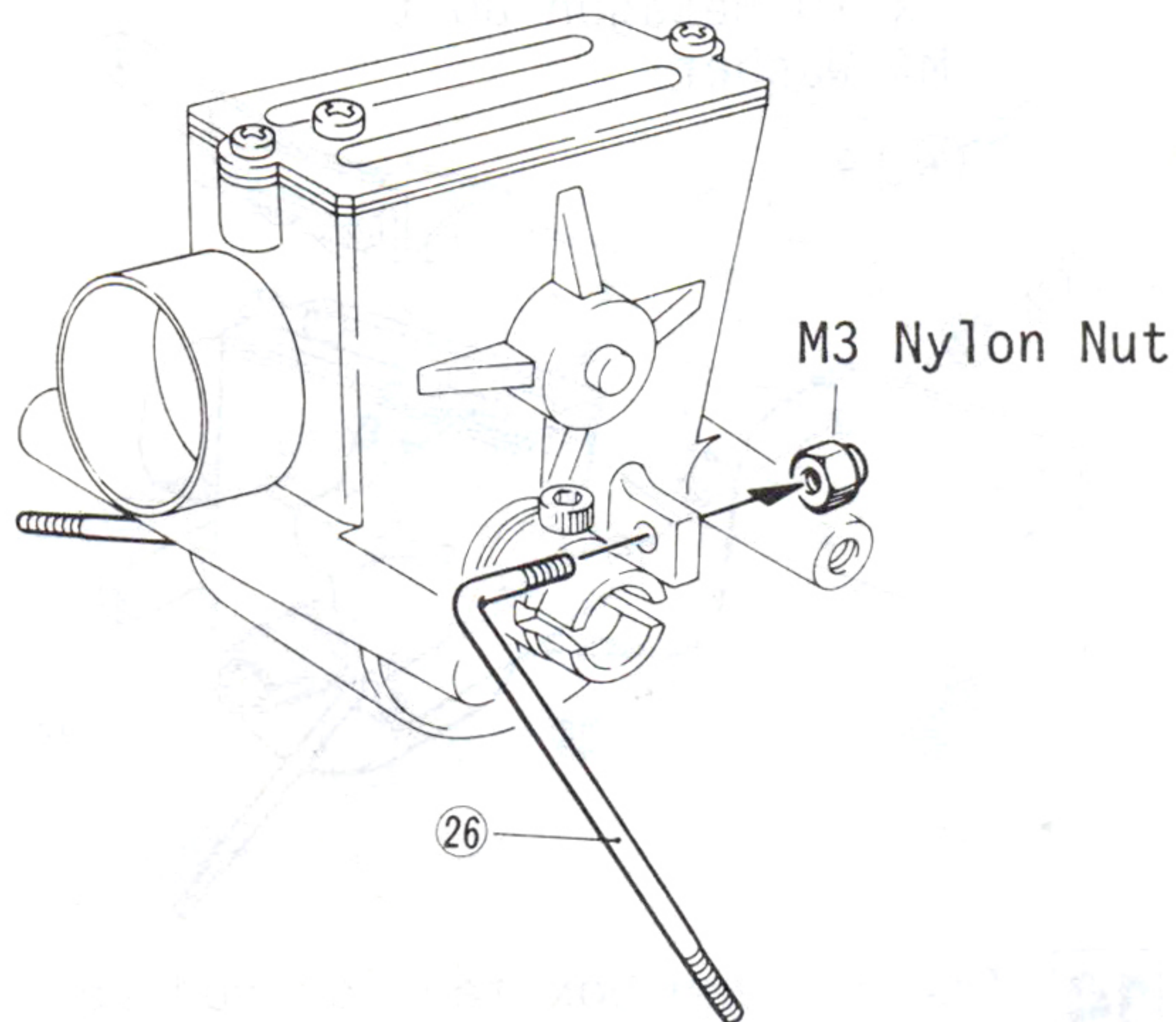
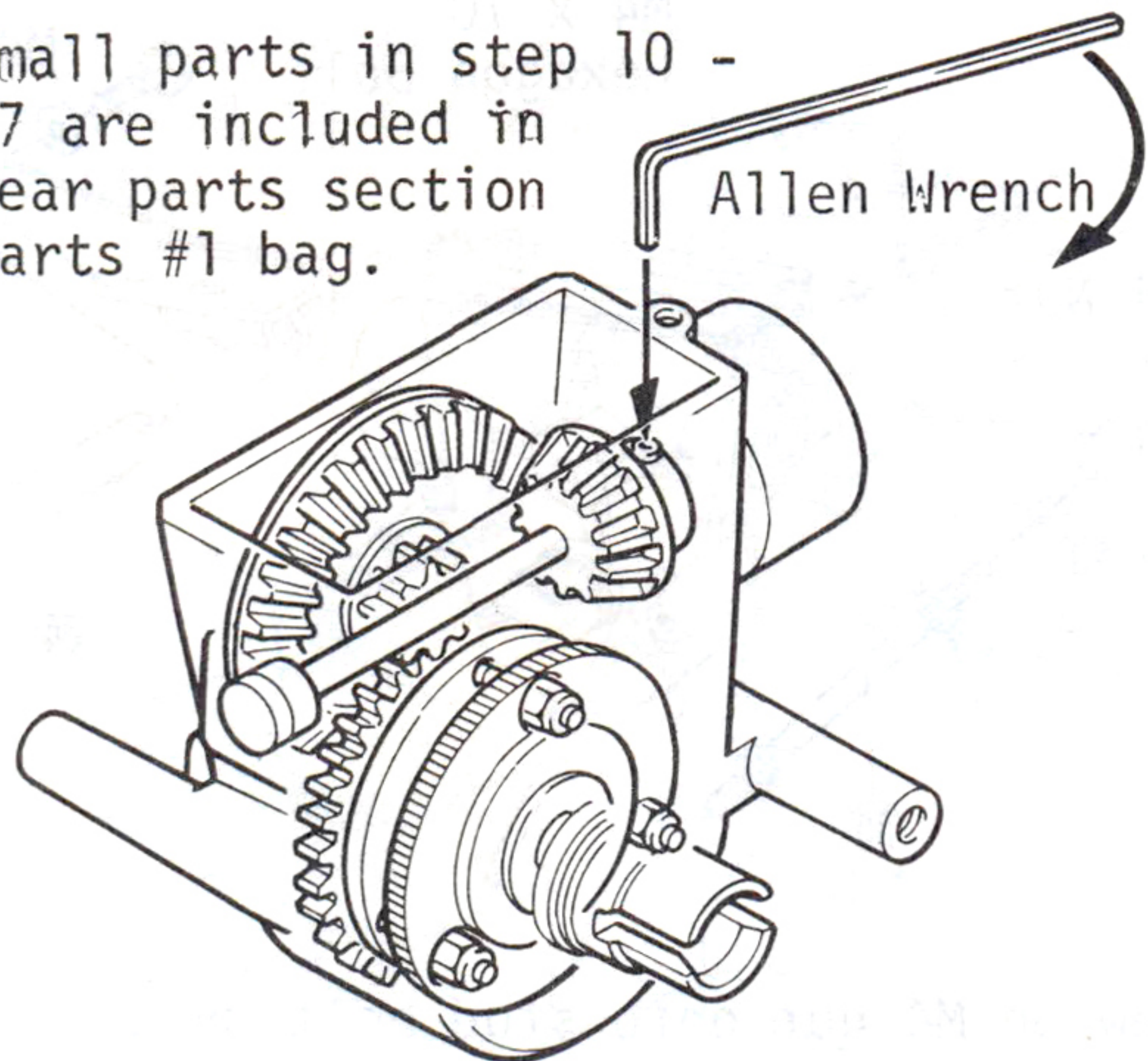

10 Gear Box is one of the most important part of this vehicle. Although it is already assembled at the factory, double check the tightness of all screws.

11 Install tension rod onto the gear box so that it will move up and down freely as illustrated.

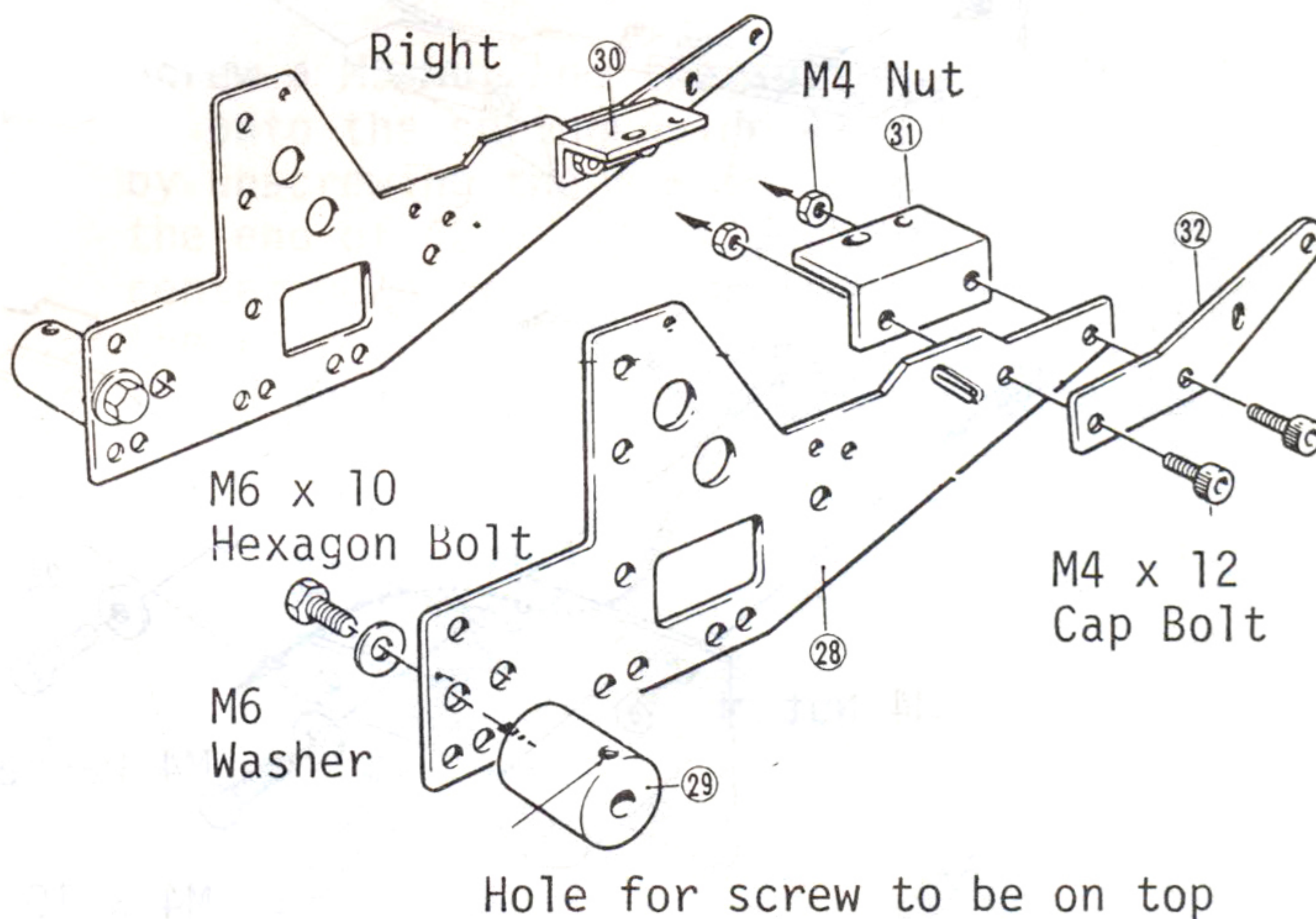
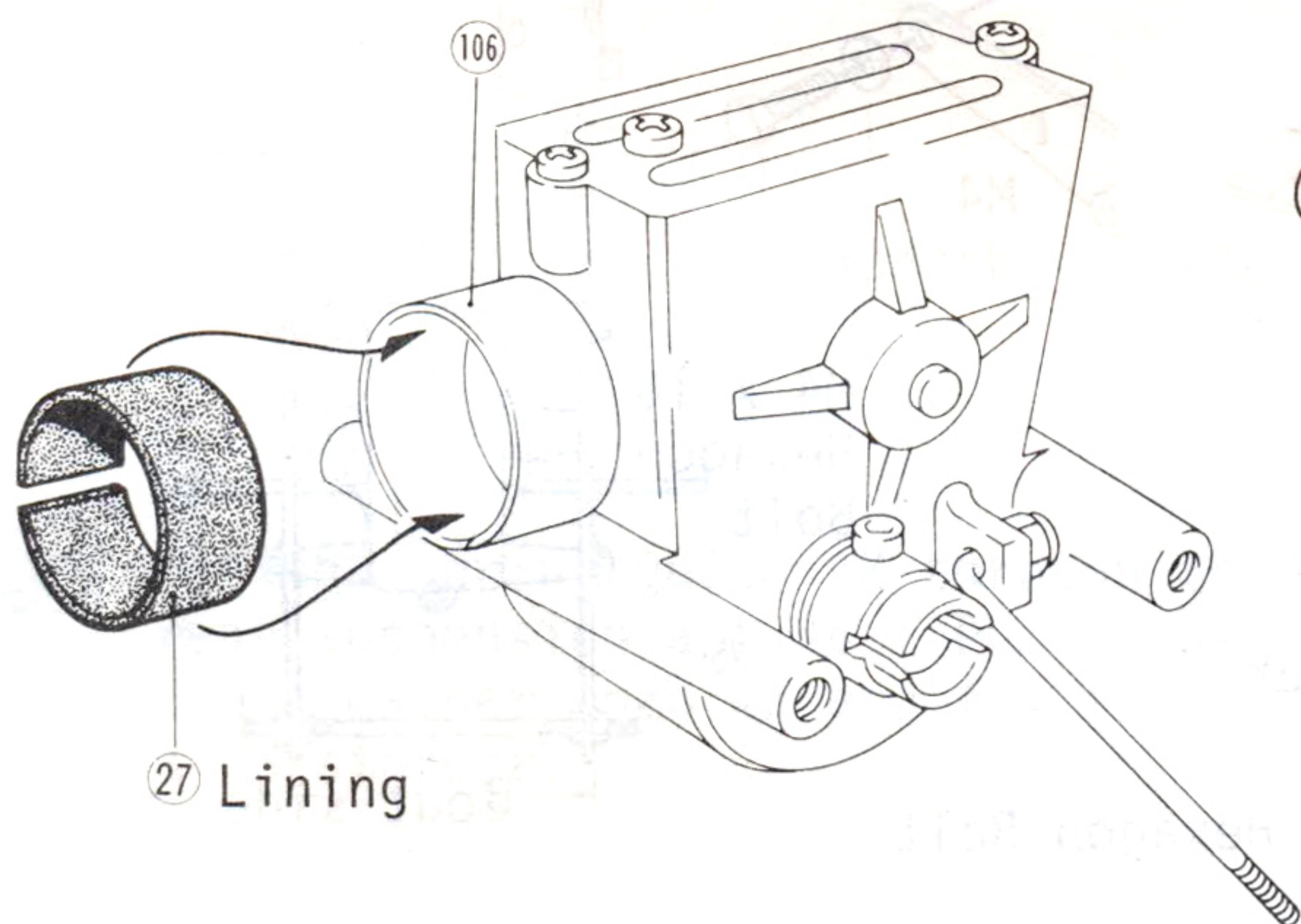

Lining 27 is fitted to the inside of clutch bell 106 but make sure that the lining is not cut too short. Also push into the clutch bell without using any adhesives. After it has been fitted in, apply small amount of cement on the joining portion. This way it will simplify the process when replacing the lining.

13 Install rear suspension pivot 29 onto rear frame 28 with M6 bolt. Engine mount 30 31 are installed together with rear bracket 32 but when doing so, be careful not to make the mistake of installing the left and right engine mount on the wrong side.

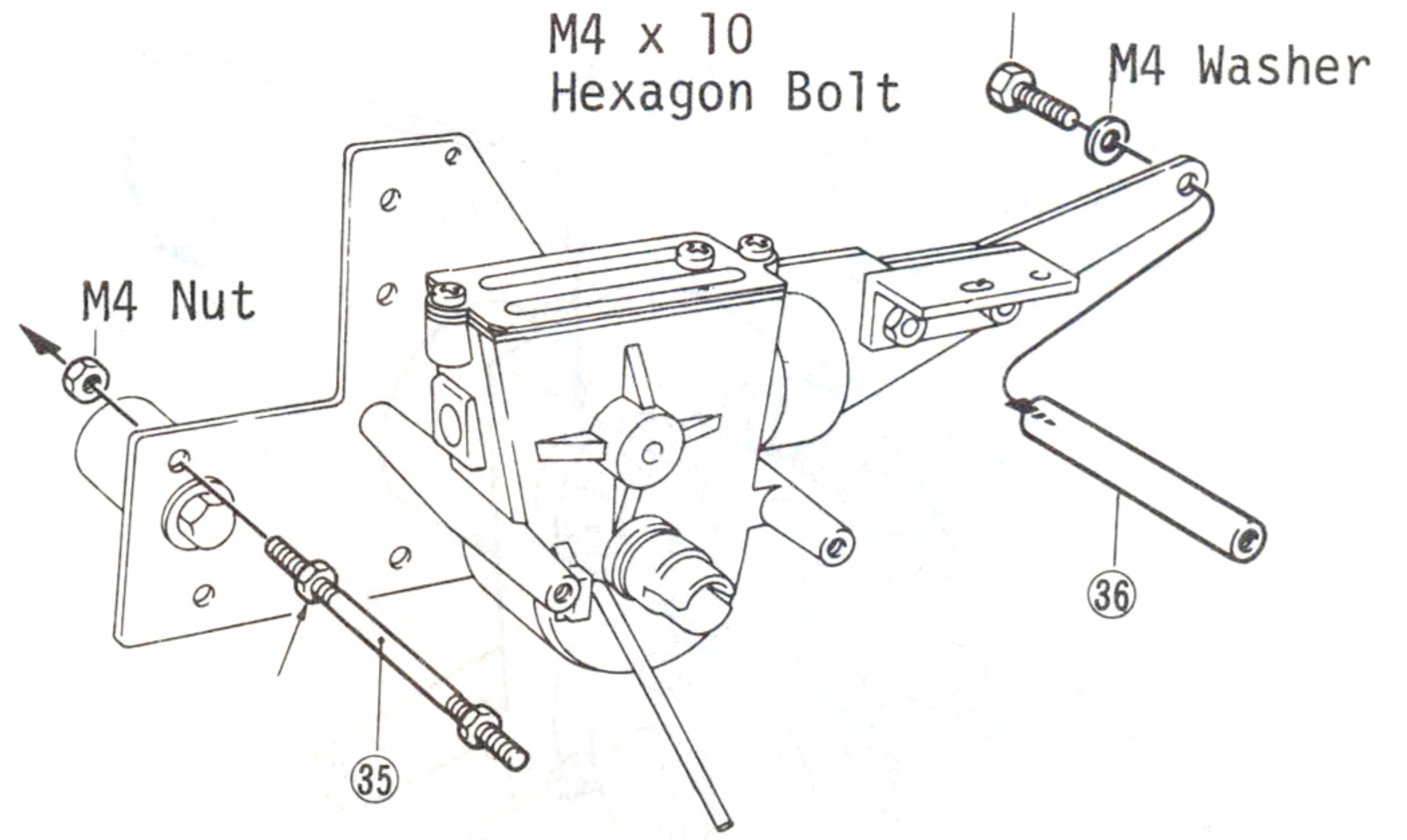
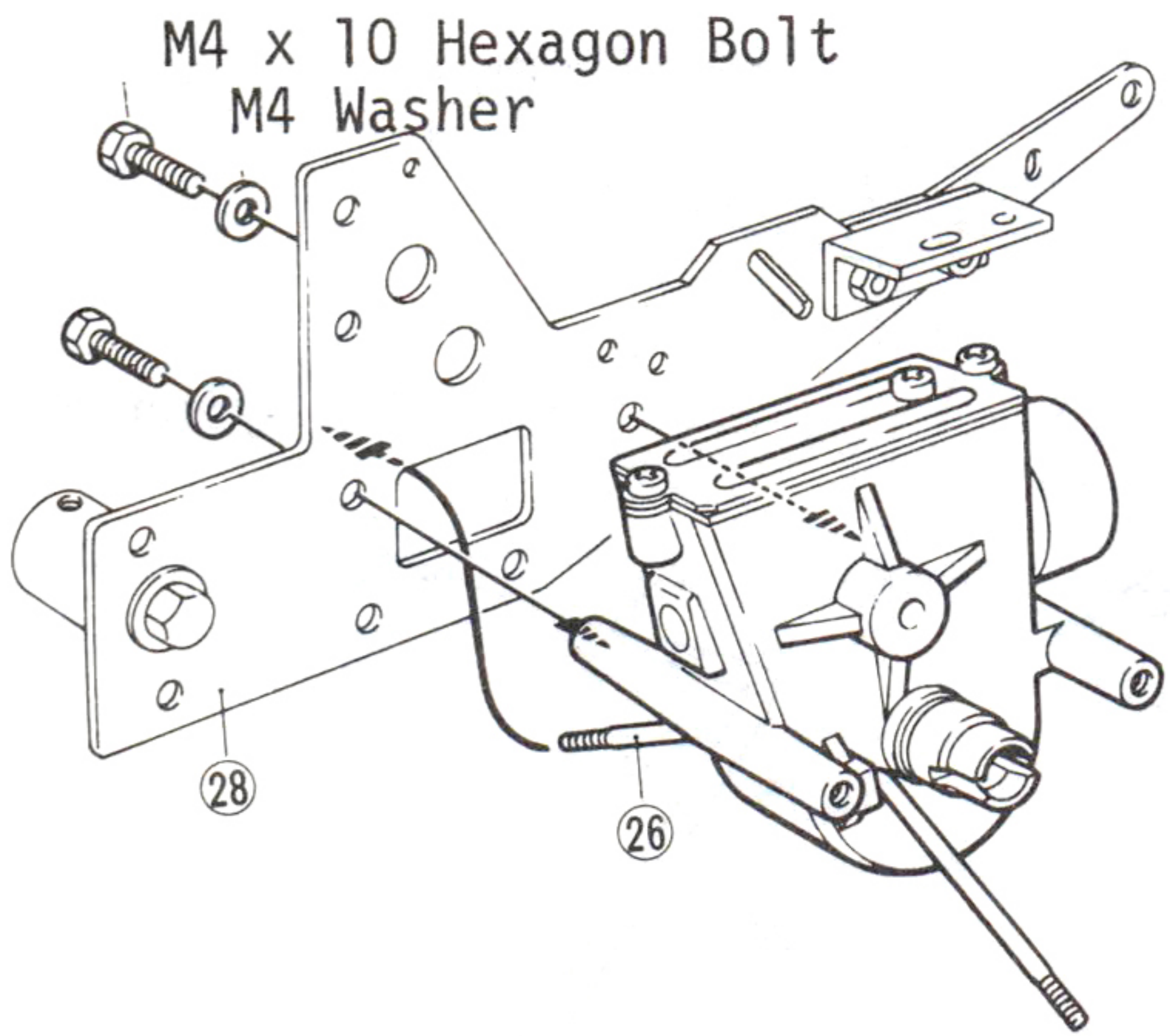

14 Insert gear box tension rod 26 through the square hole in the rear frame 28 and then install the gear box assembly onto rear frame 28.

15 Screw on M4 nut onto stud bolt 35 as illustrated, and have stud bolt 35 temporarily attached to one side of the rear frame with M4 nut. Also, have rear bracket joint 36 installed as well.

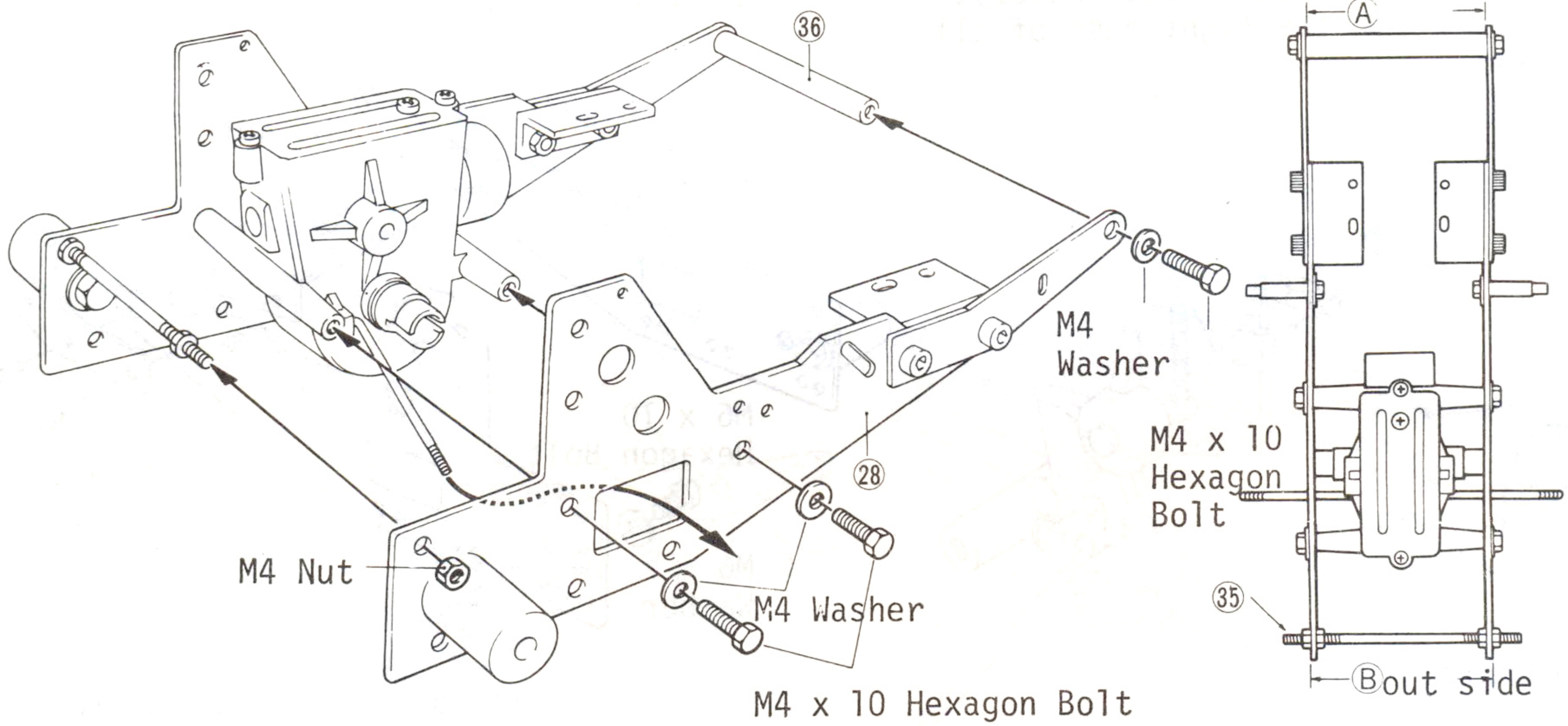

16 The other side rear frame 28 is installed as illustrated but tighten by adjusting the M4 nut on the stud bolt 35 so that the A B will be parallel as illustrated.

Use by cutting the fuel line pipe to 5mm length.

Bend as shown in illustration.

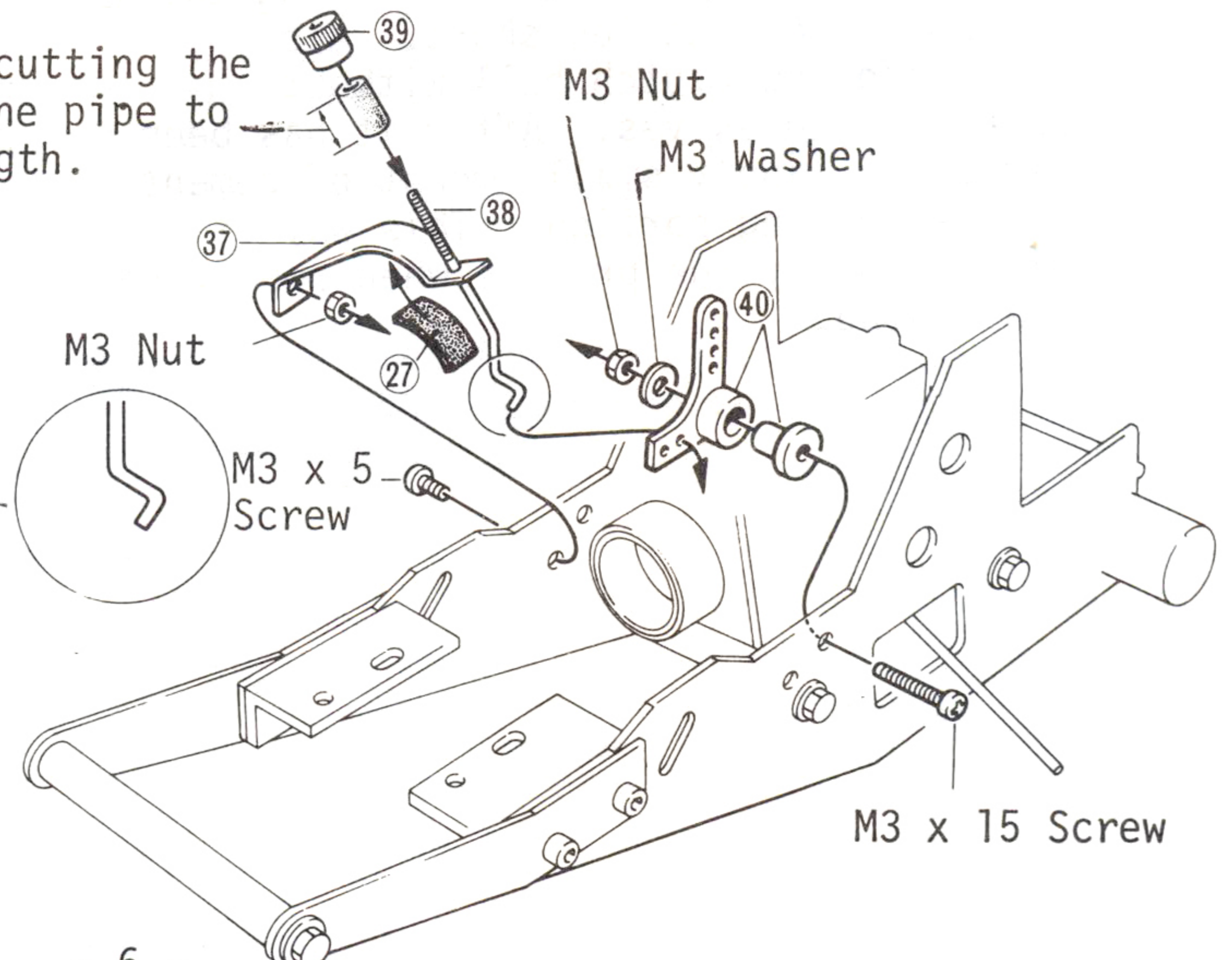

17 Cement lining 27 onto brake shoe 37 then install brake and "L" crank 40 as illustrated. Screw in brake adjuster 39 into brake rod 38.

Small parts for step 18 - 24 included in the rear parts #2 bag.

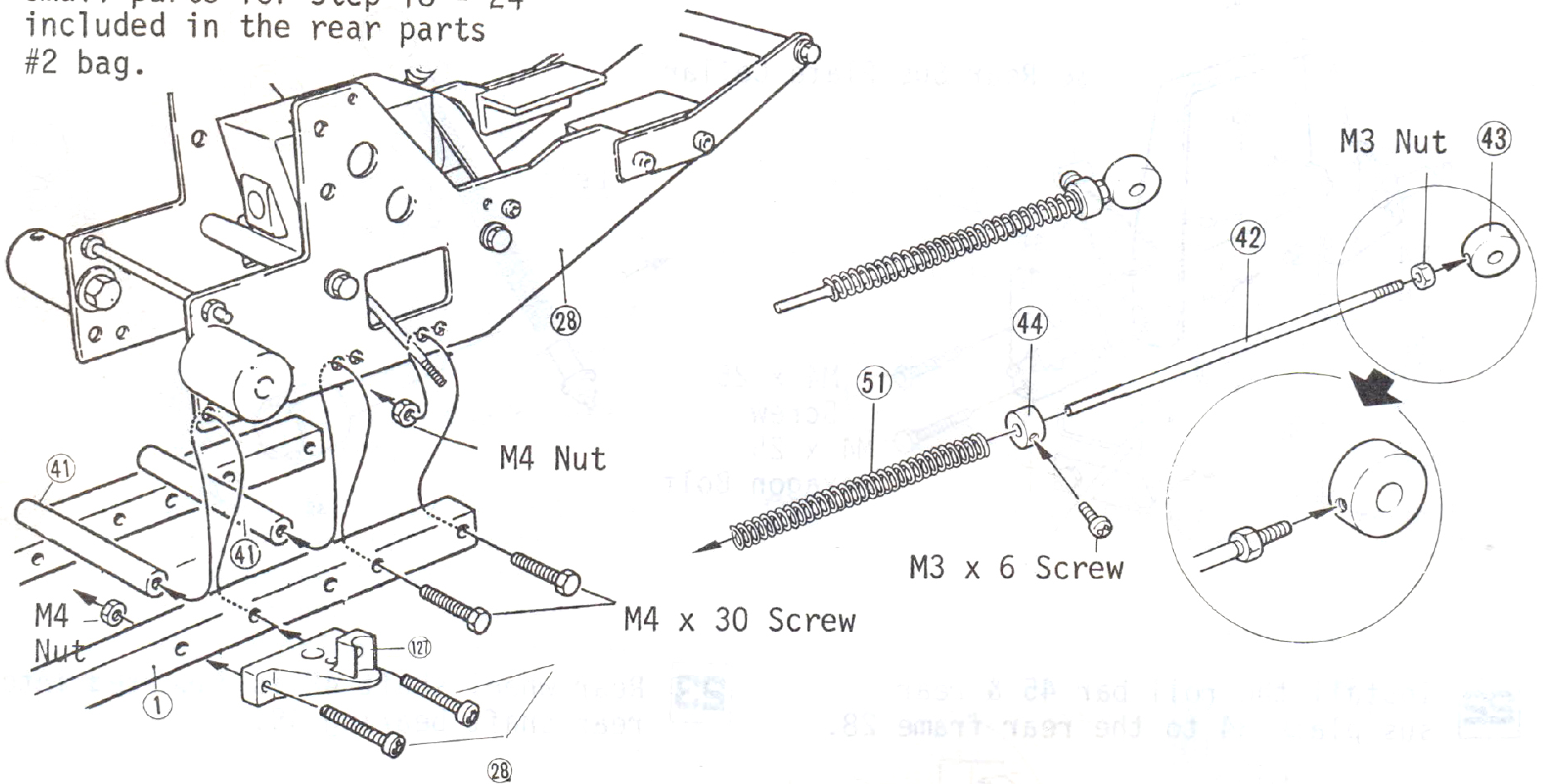

18 Install rear frame 28, side member 127, joint Collar 41 onto main frame 1 as illustrated.

19 Screw a M3 nut and the spring guide end 43 in onto the spring guide 42. Lock the 43 by unscrewing the nut in such a way that the end of 42 will not protrude into the center hole of 43. Put the stopper 44 and the rear spring 51 onto 42. 44 should be fixed tentatively for the later adjustment.

20 Fit the spring guide 42 through the rear suspension arm 46. Put a thimble and a washer onto 42 and fix it with a M3 stopper.

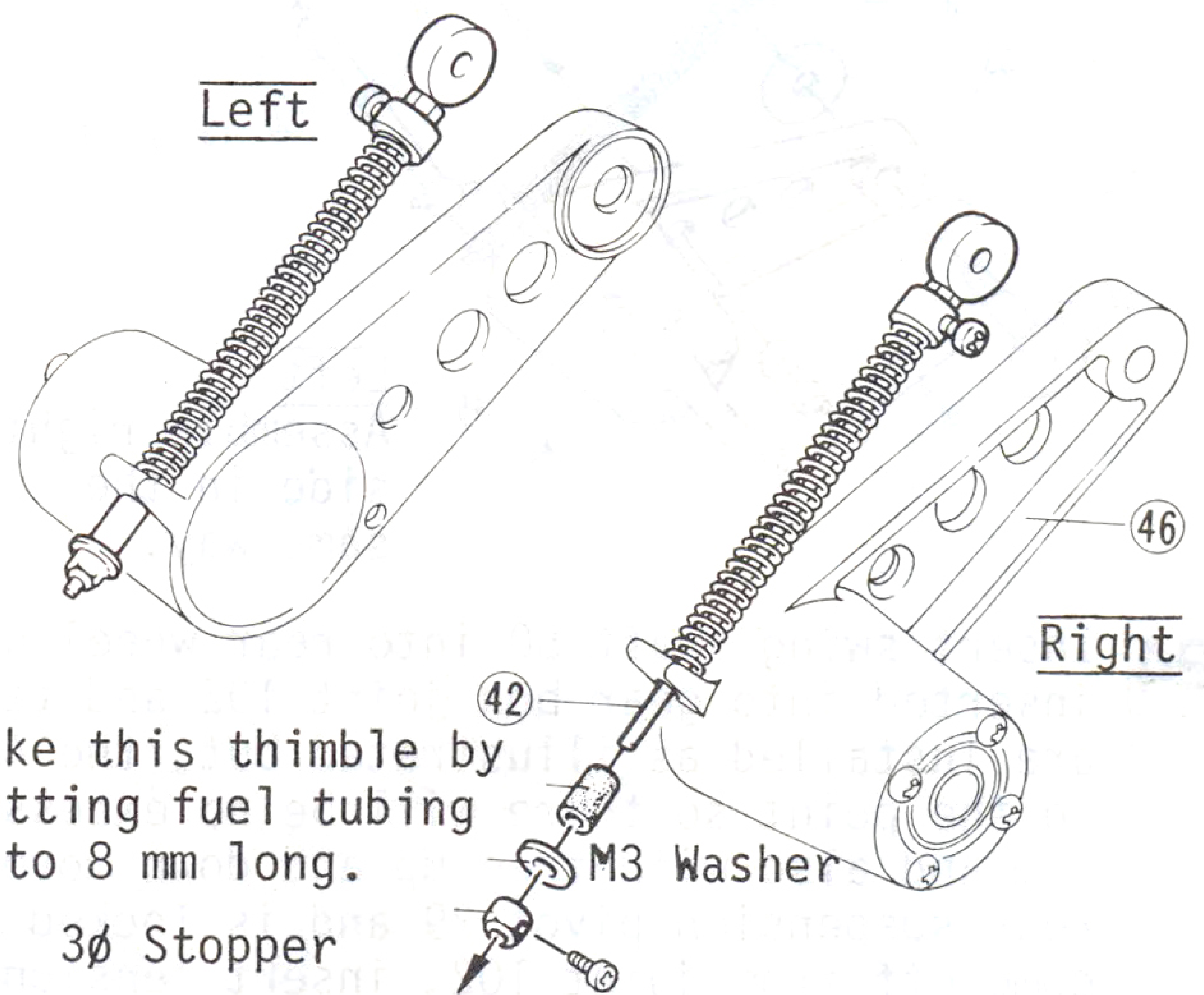

Make this thimble by cutting fuel tubing into 8 mm long.

3ø Stopper

When a damper is employed, this screw should be attached beforehand. (The screw and nuts are packed with the Stopper.)

21 Install the rear suspension holder to the rear suspension plate 34.

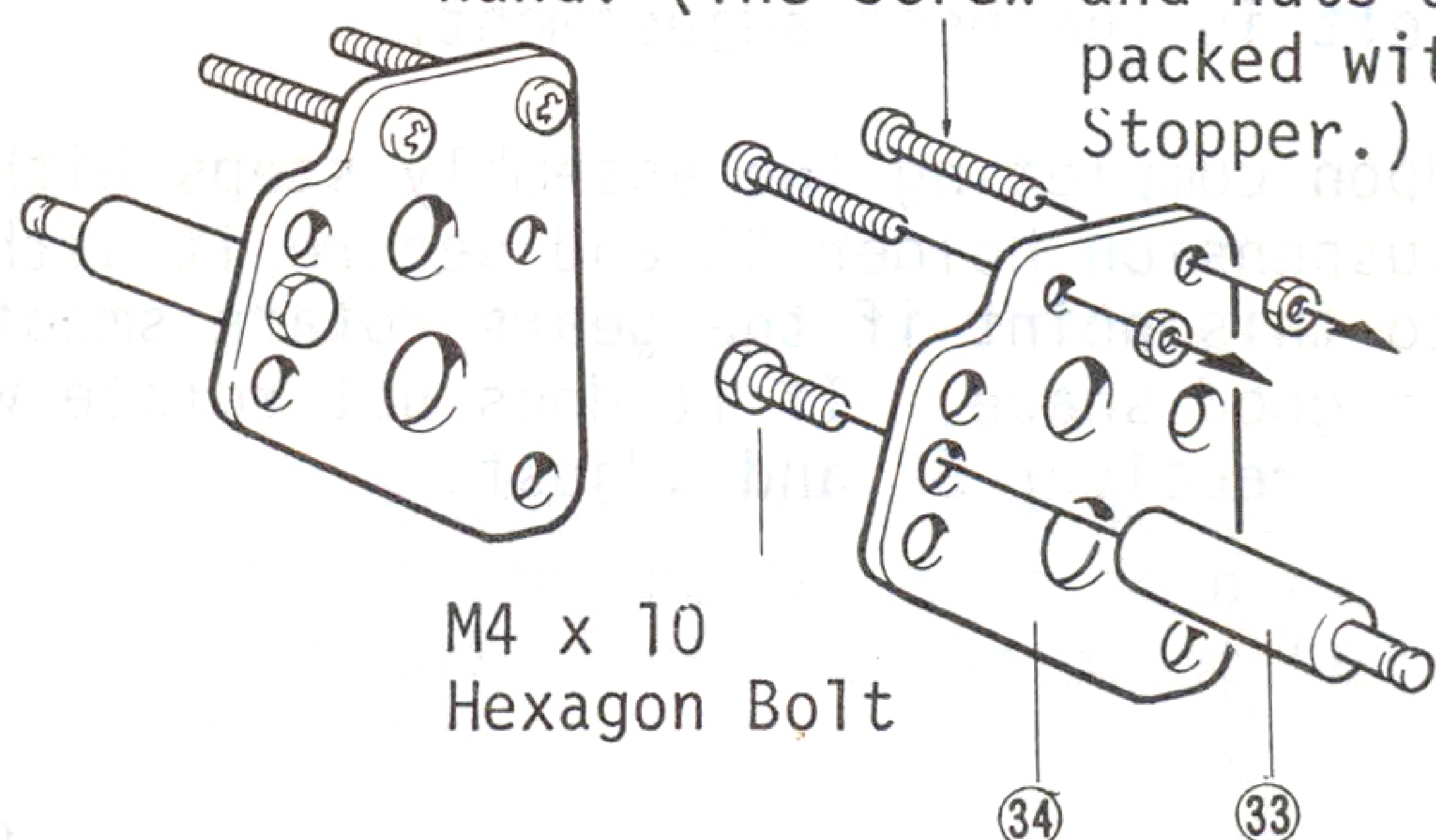

M4 x 10 Hexagon Bolt

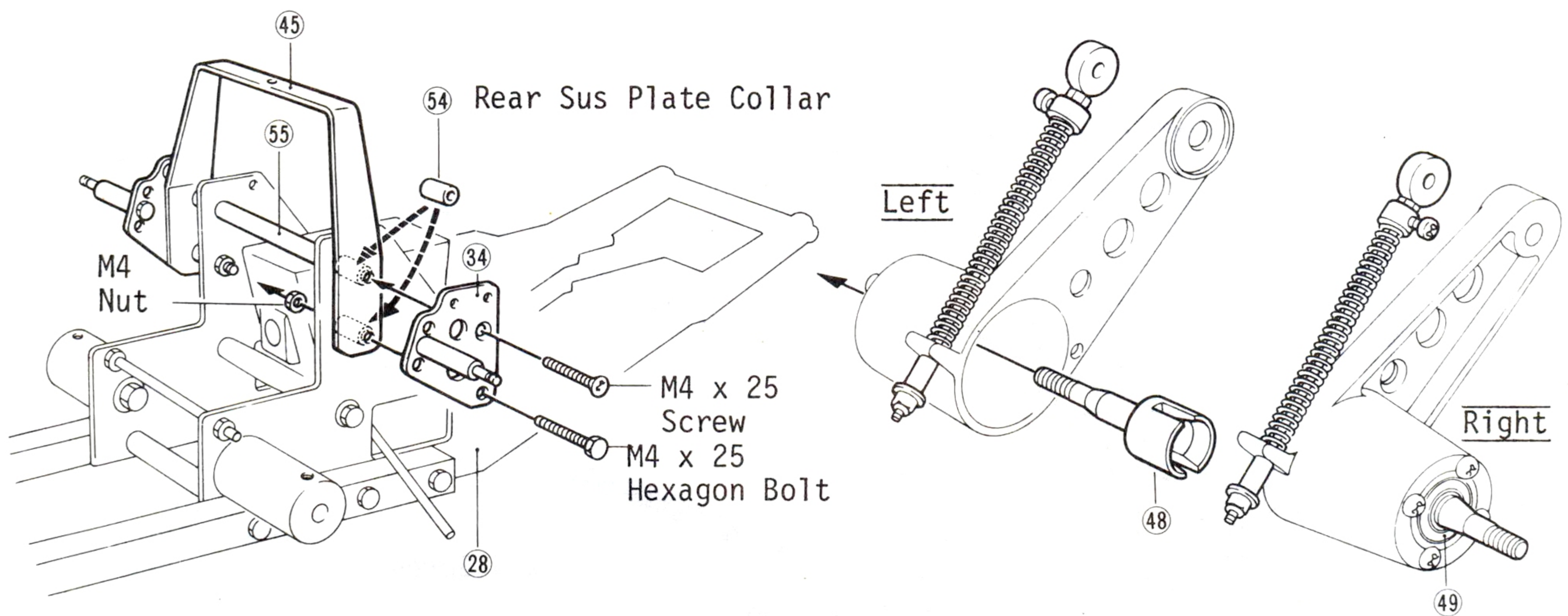

22 Install the roll bar 45 & rear sus plate 34 to the rear frame 28.

23 Rear wheel shaft 48 is inserted into rear shaft bearing 49.

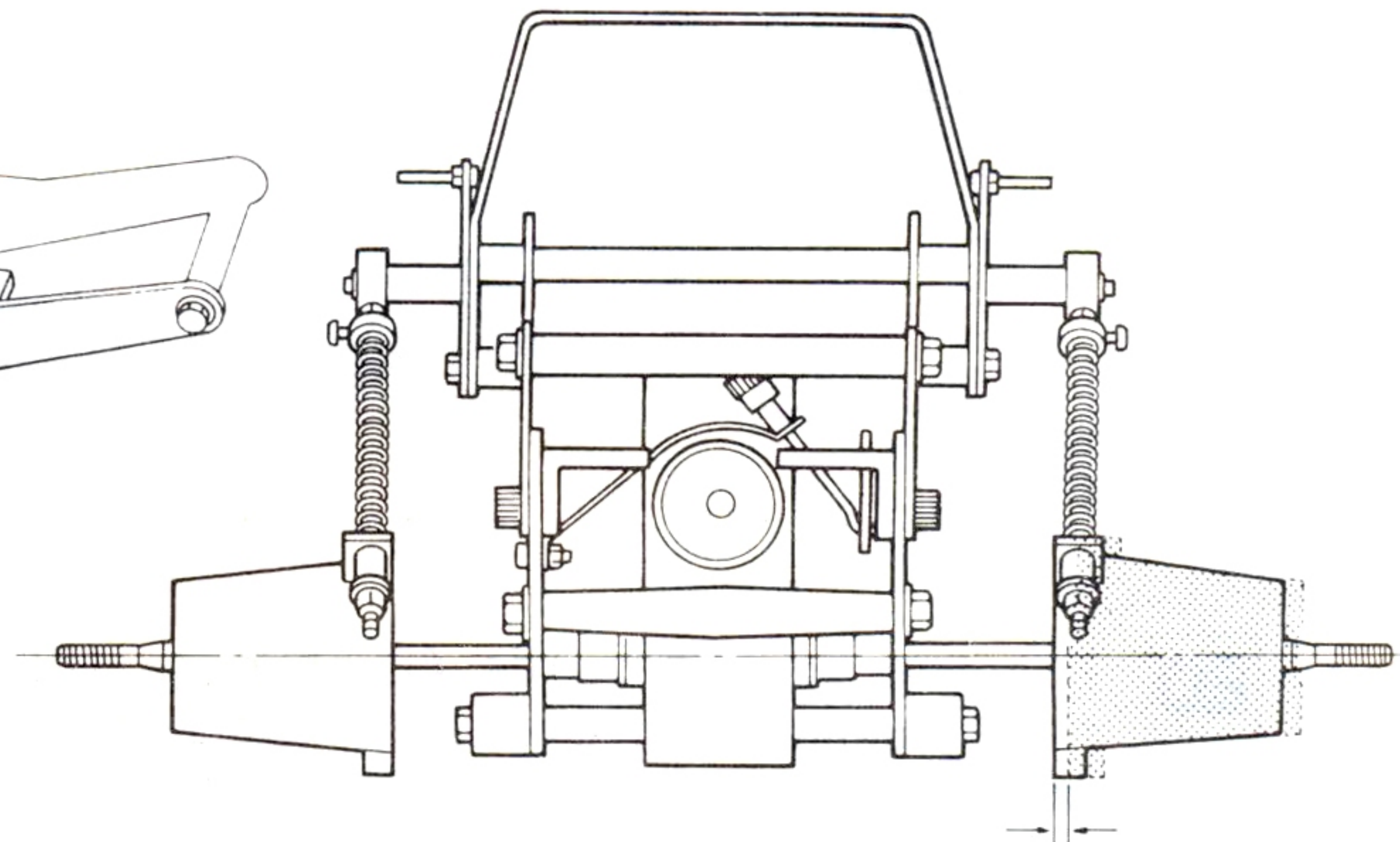
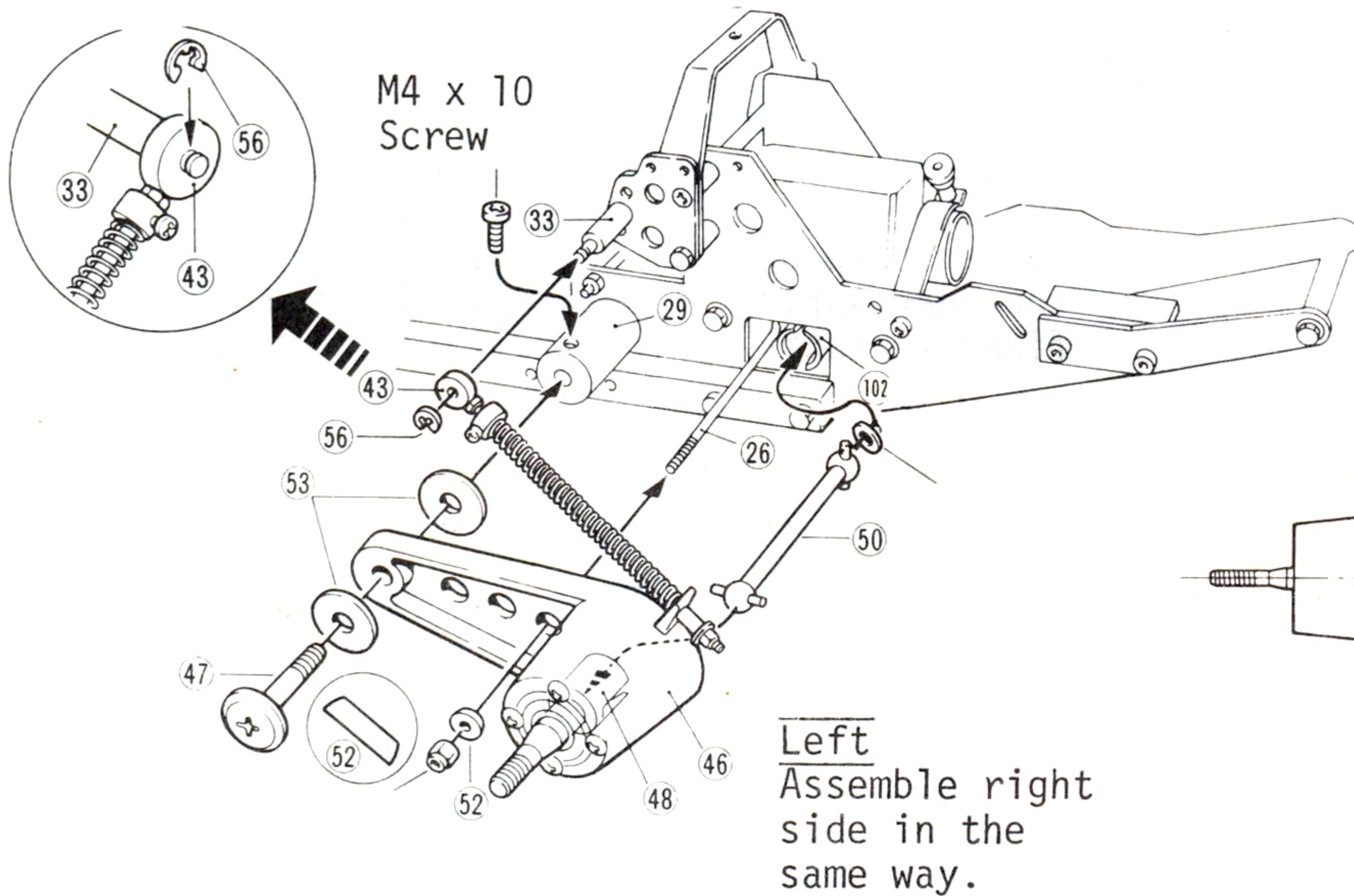

Leave a play of about 1mm on right and left side with swing arm in horizontal position.

24 Insert swing shaft 50 into rear wheel shaft 48, the other end of swing shaft is inserted into gear box joint 102 and tension rod 26 and rear suspension shaft 47 are installed as illustrated but, the 47 rear suspension shaft should be tightened to the point so there will be no excess play to left and right on the suspension arm and also with free up and down movement, then M4 x 10 screw is screwed into rear suspension pivot 29 and is locked with 47. So that swing shaft 50 will not come off from joint 102, insert tension rod receiver 52 into tension rod 26, and tension rod 26 is pulled tight with nylon nut M3. However, if pulled too tight, the movement of the rear suspension arm will become sluggish. In the position as shown in the right illustration condition with about 1mm play on the right and left is the best adjustment.

Upon completing the assembly steps hitherto, put the rear spring over the rear suspension holder 33 and secure it with a E-ring. All assembly work completed to this point if the gears rotate smoothly when turned with your finger, it is in good shape. If it does not rotate well, loosen M3 nut holding the tension rod receiver 52 and adjust.

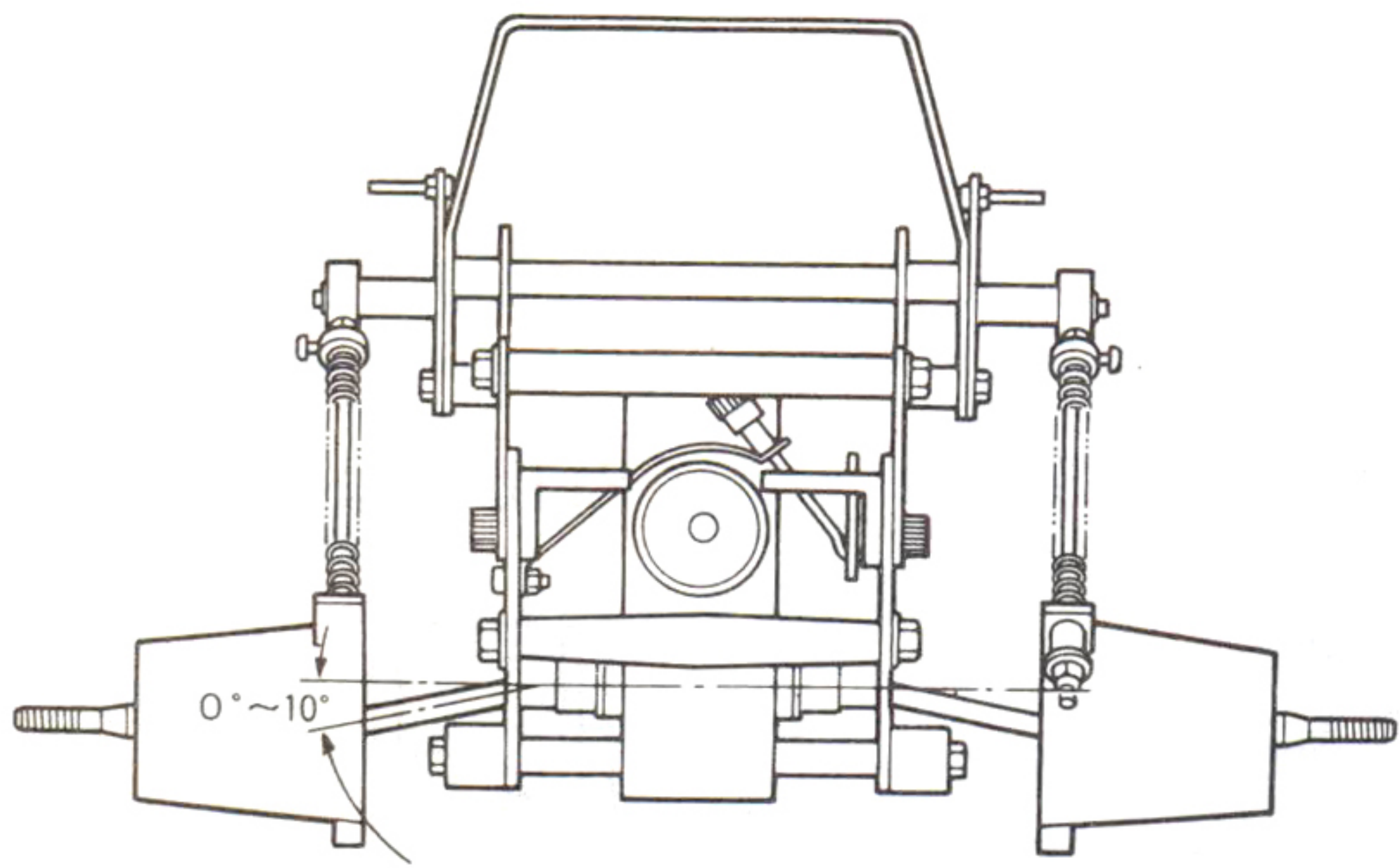

Arrange the swing shafts horizontal or slightly downward.

25 Do not arrange the body height too high. Set it in such a degree that the swing shaft will be situated horizontal or downward to 10° when looking at the chassis from behind.

27 First, cut off with back saw or grinder leaving 17 mm measuring from the tip of the shaft to the engine drive shaft. After this has been done, install flywheel 58 firmly illustrated.

When using Enya 21 X engine engine wrap shim 115 around shaft insert flywheel.

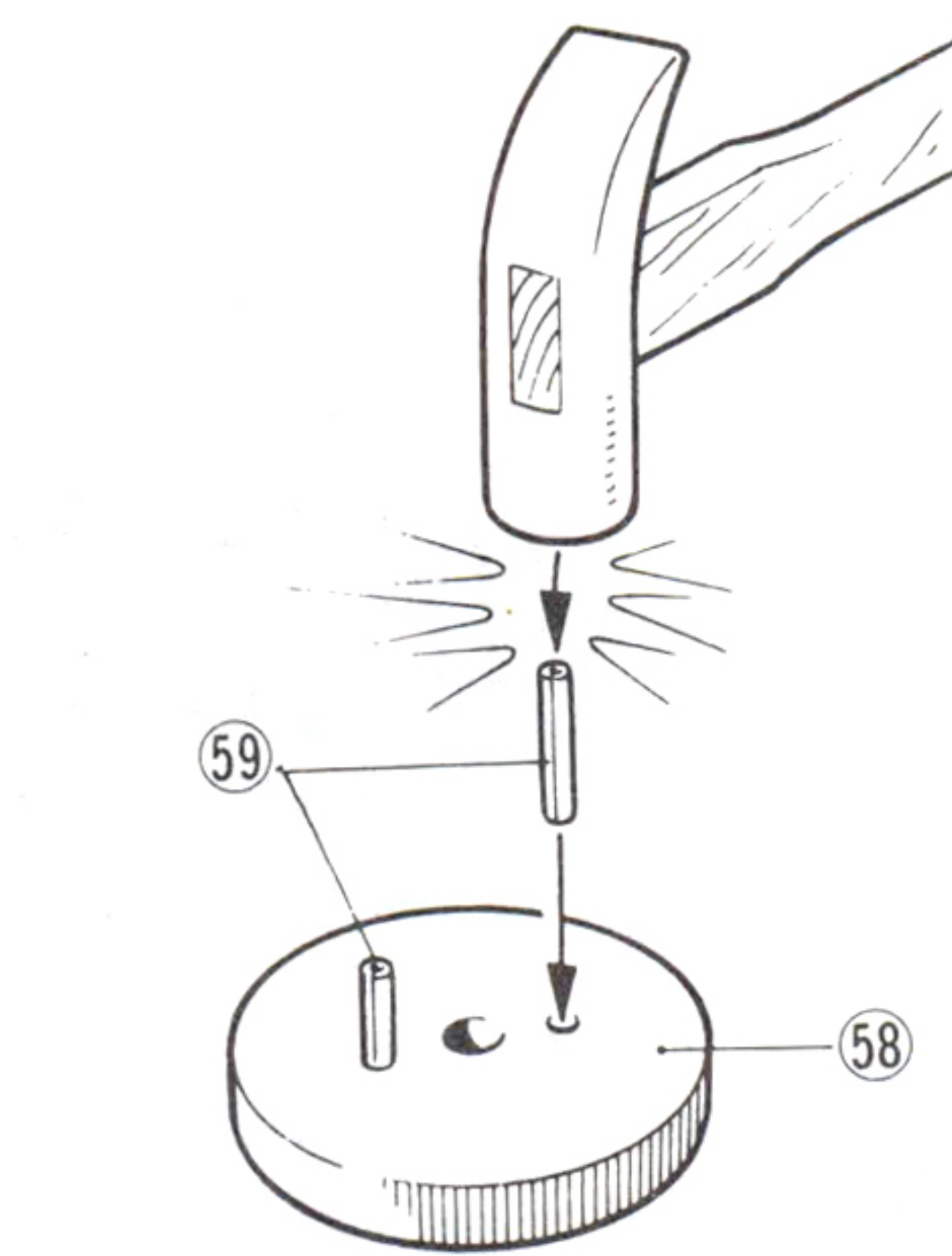

Small parts for steps 26 - 28 are included in engine parts bag.

26 Top in clutch pin 59 into flywheel 58.

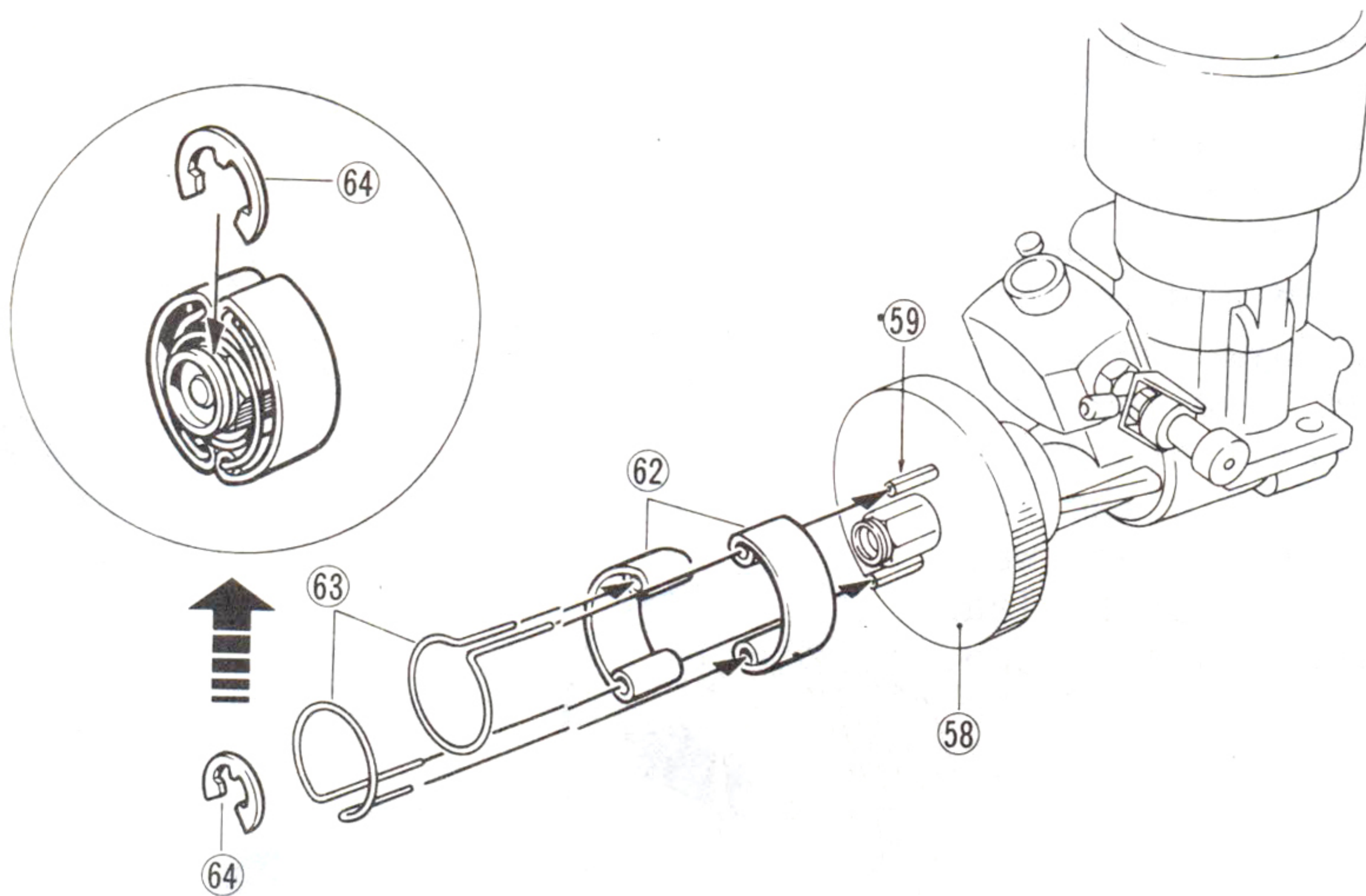
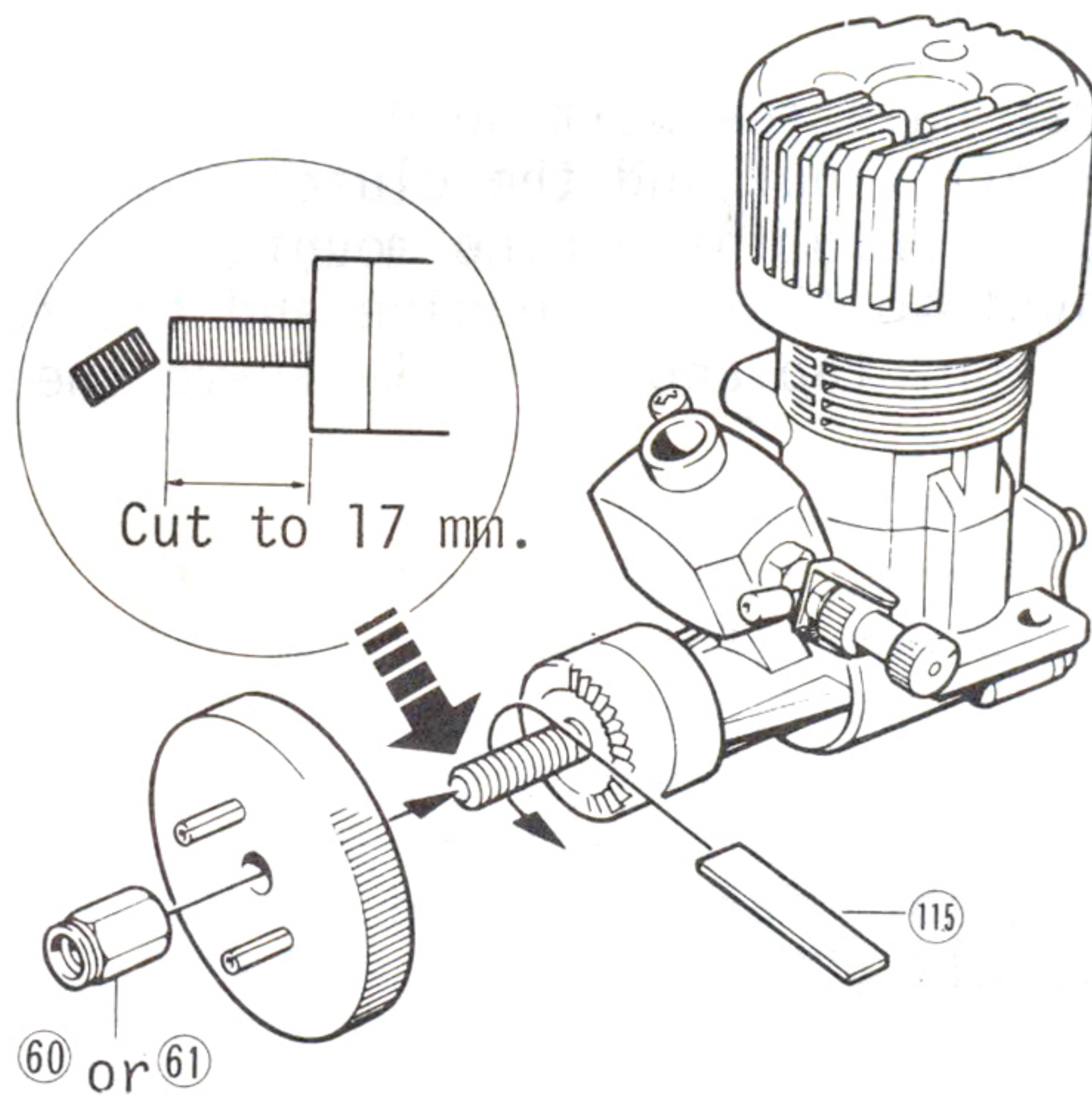

28 Insert clutch shoe 62 into clutch pin 59, as illustrated, insert the longer side of the clutch spring 63 into clutch pin 59 hole and the shorter side into clutch shoe 62 hole. And finally fit into the groove of the pilot nut the pilot "E" ring 64 and make it so that the spring will not come off.

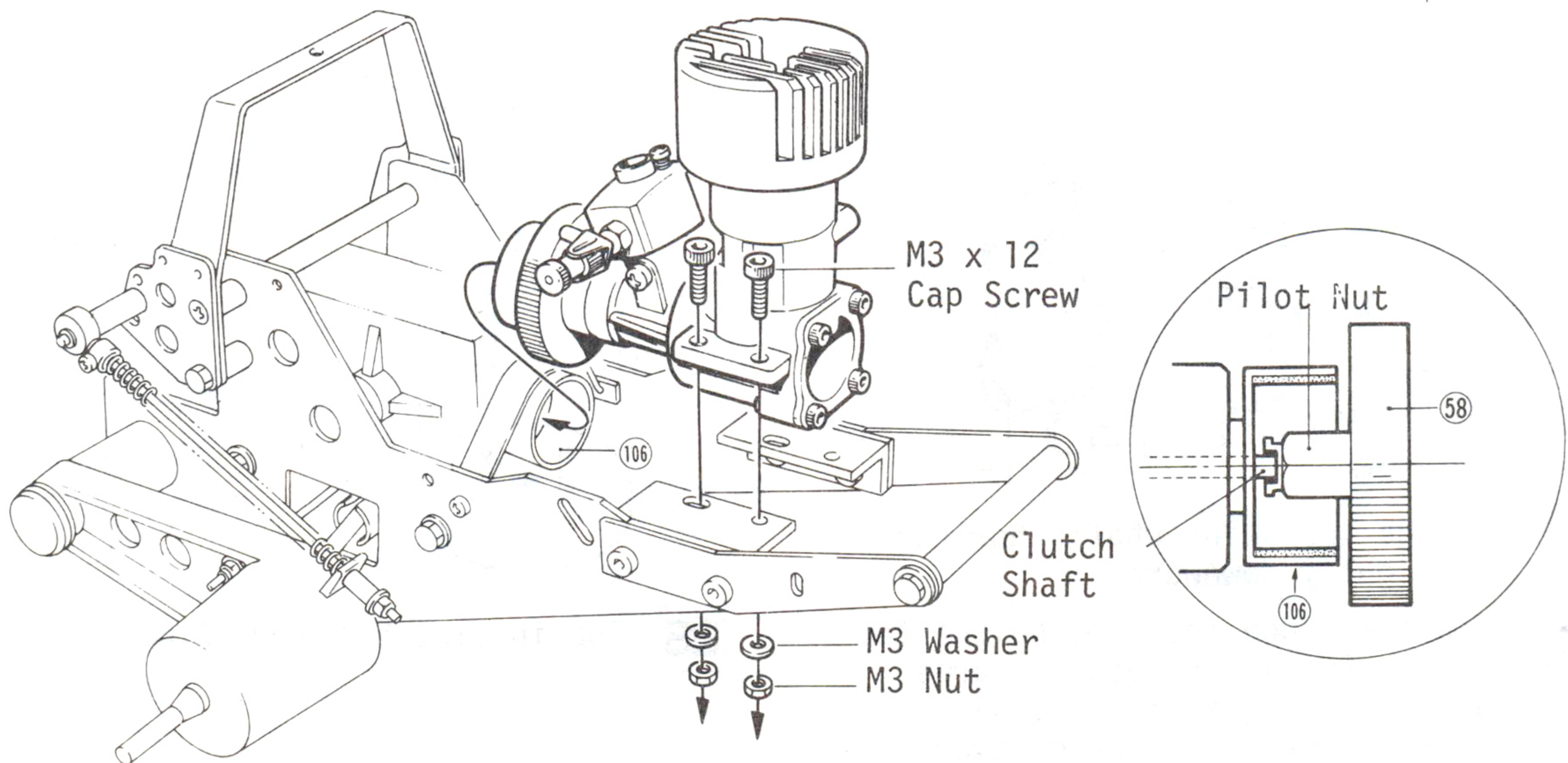

29 First have the bolt holding the engine mount loosened, align the center hole of the pilot nut and the clutch shaft of the clutch bell 106 and then install the engine onto the engine mount. At this time, as each bolts are being tightened adjust so that the engine and the frame will become parallel looking at it from straight top and directly frame the side.

30 Muffler is installed but, please note that there is a special muffler for circuit being sold as an optional parts. It is made interchangeable for OS-21 and Enya 21X (CB-110).

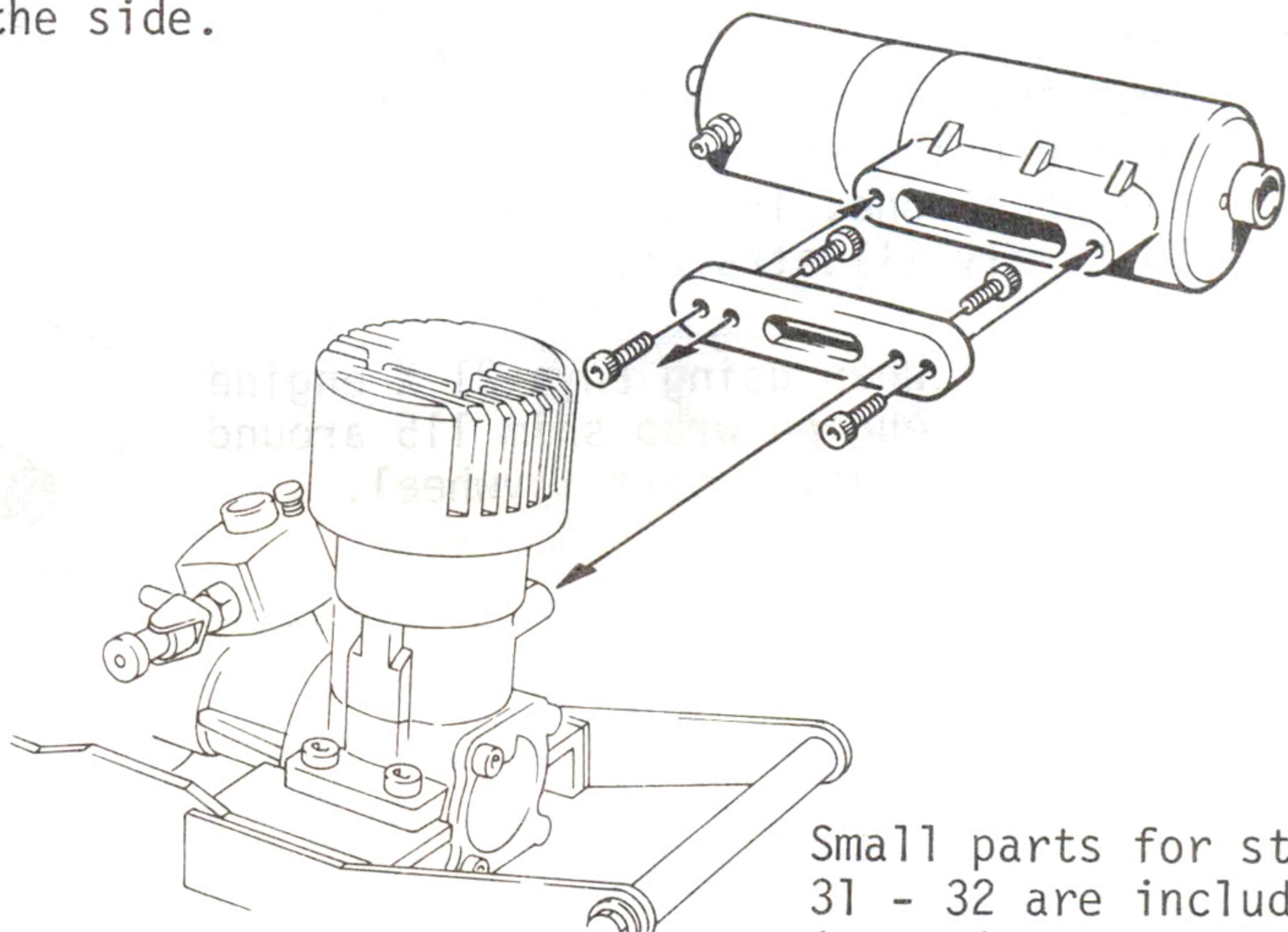

31 Wheels are cemented onto front and rear tires but to do this, the best way is to apply a light coat of rubber type cement to the cementing surface of both the wheel and tire and let it dry for about a day. Next, apply thinner or gasoline to the surface where it has dried than insert wheel into the tire and let it dry. This way, you will be able to get a clean and perfect cementing job done. Also, it would be better if the cementing surface of the wheel is roughened with sand paper for stronger adhesiveness. Insert drive washer 70 into the rear wheel and front wheel bearing into the front wheel.

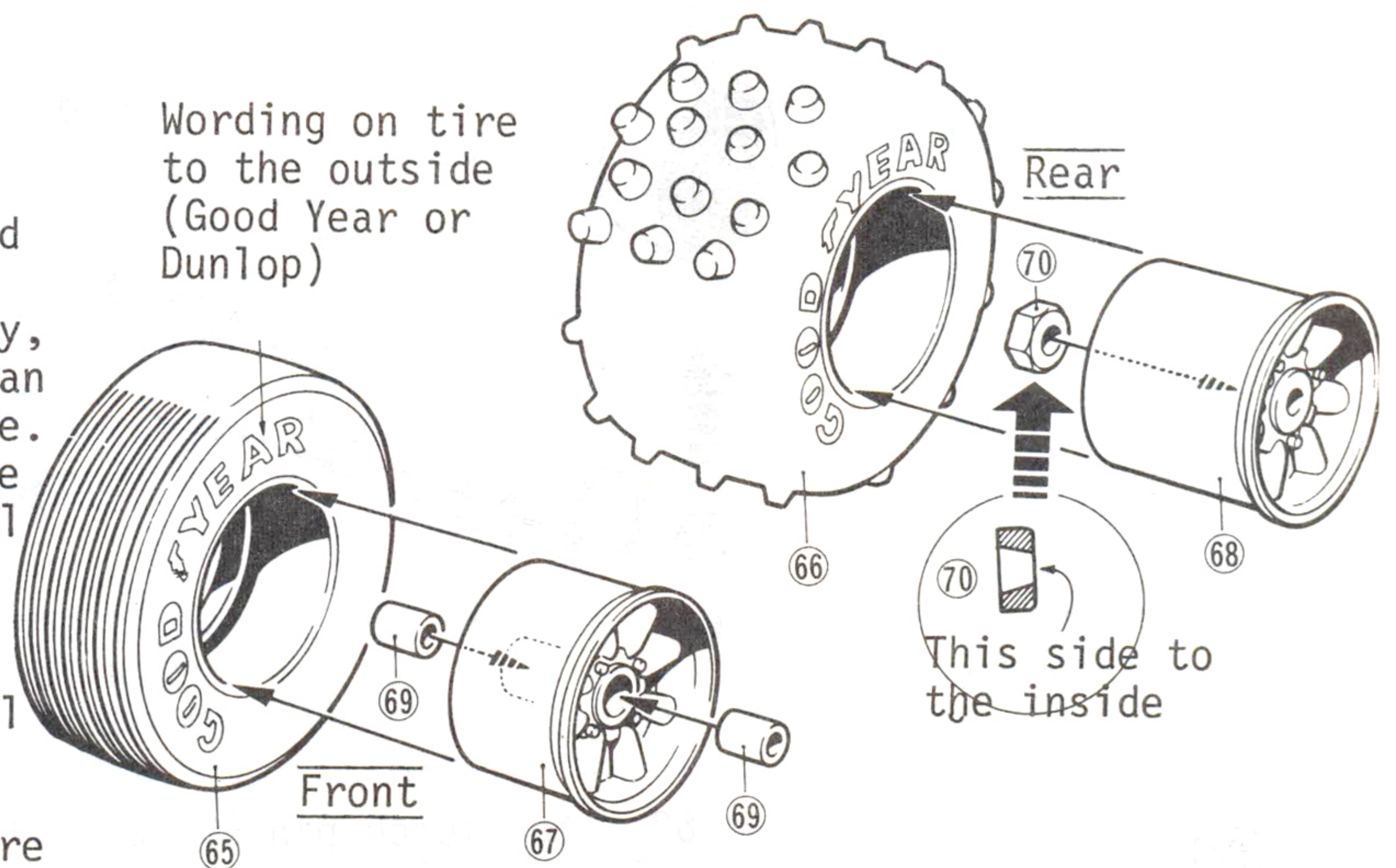

Small parts for steps 31 - 32 are included in engine parts bag.

Small parts in step 31 - 32 are included in Wheel parts bag.

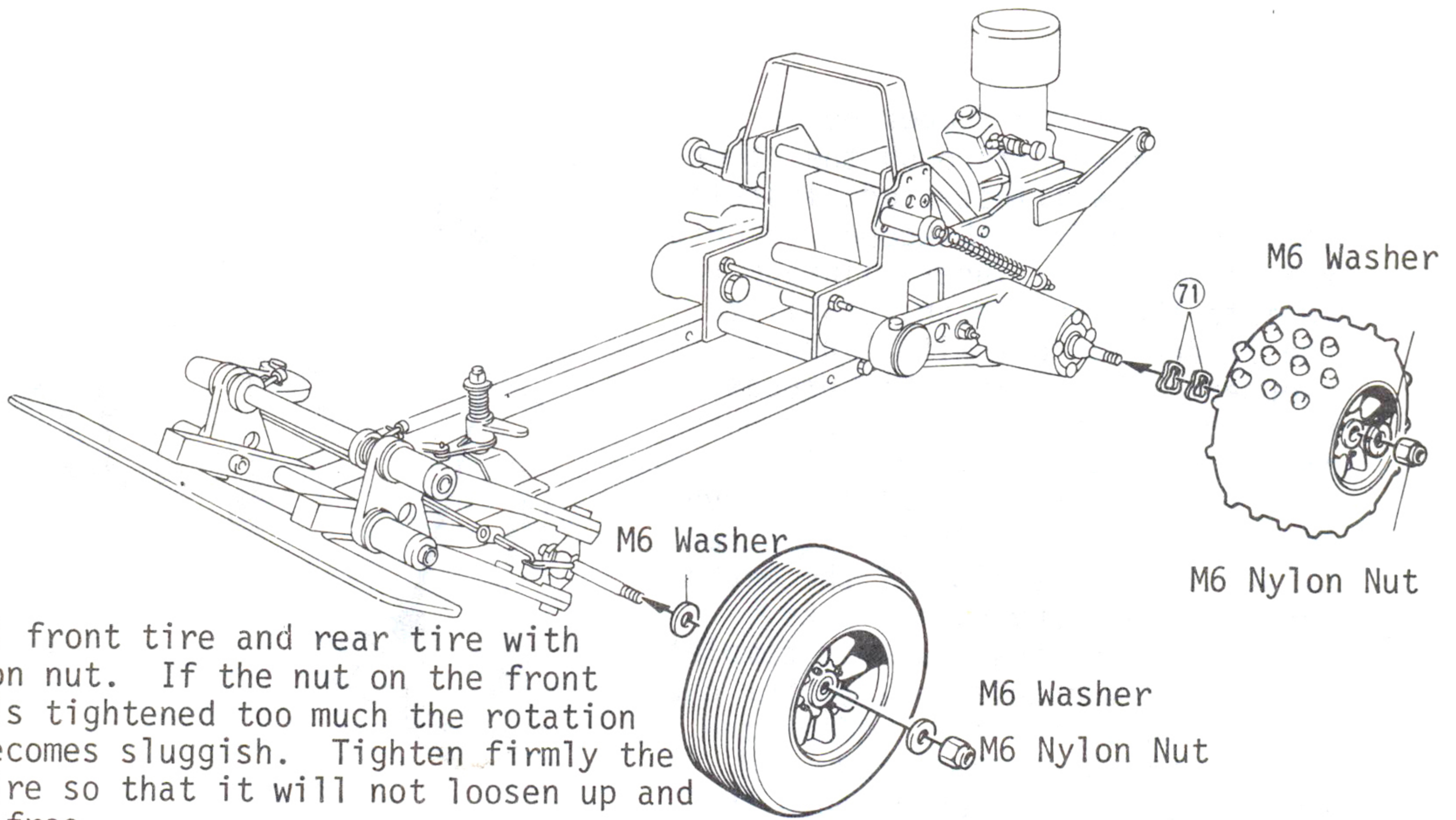

32 Install front tire and rear tire with M6 nylon nut. If the nut on the front wheel is tightened too much the rotation will become sluggish. Tighten firmly the rear tire so that it will not loosen up and become free.

Small parts for steps 33 are included in fuel tank bag.

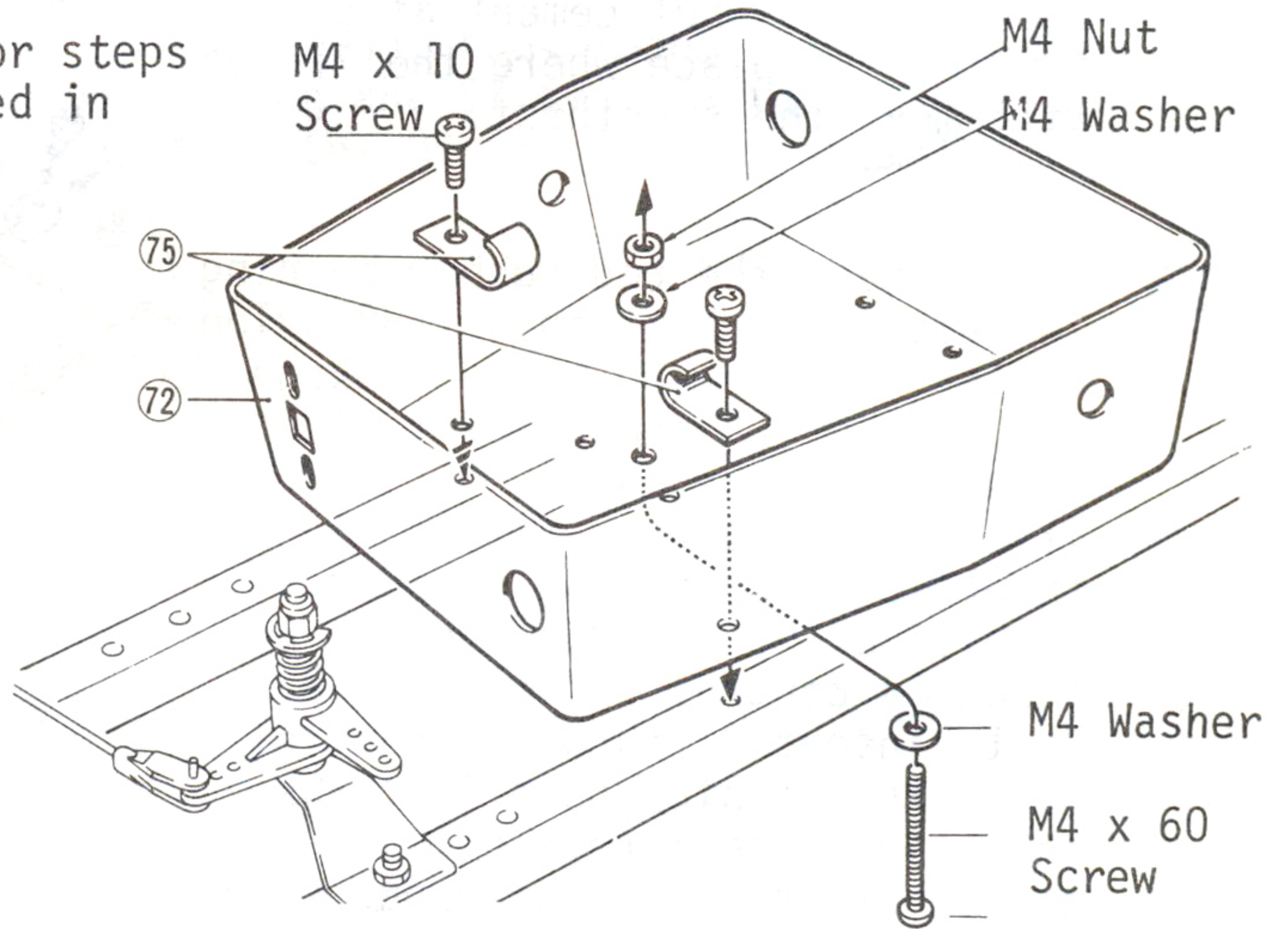
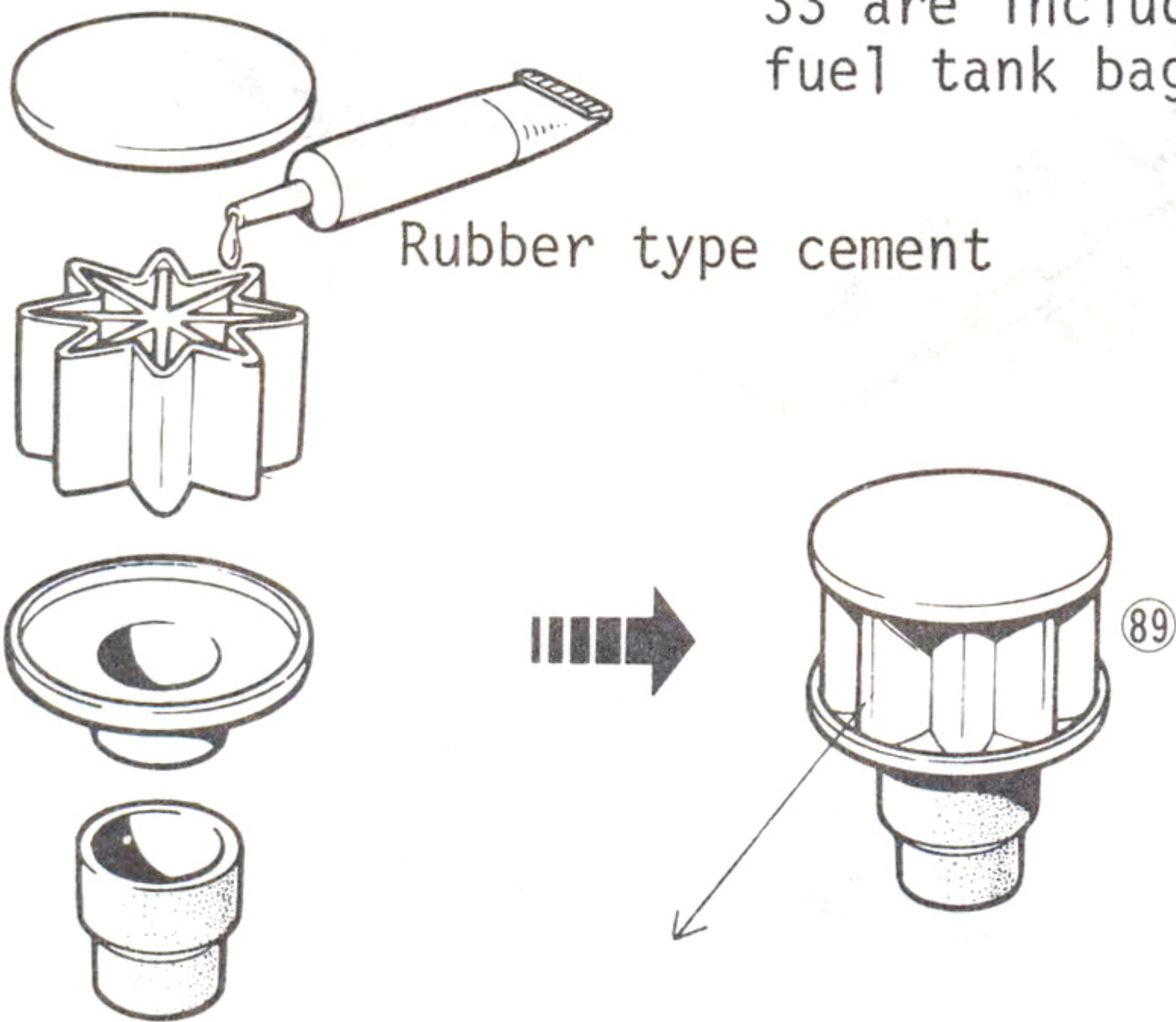

33 Air filter 89 is assembled by cementing together with a cement as illustrated.

34 Battery holder hardware 75 together with mechanism box 72 are installed onto the frame.

Small parts for steps 34 - 39 are included in linkage parts bag.

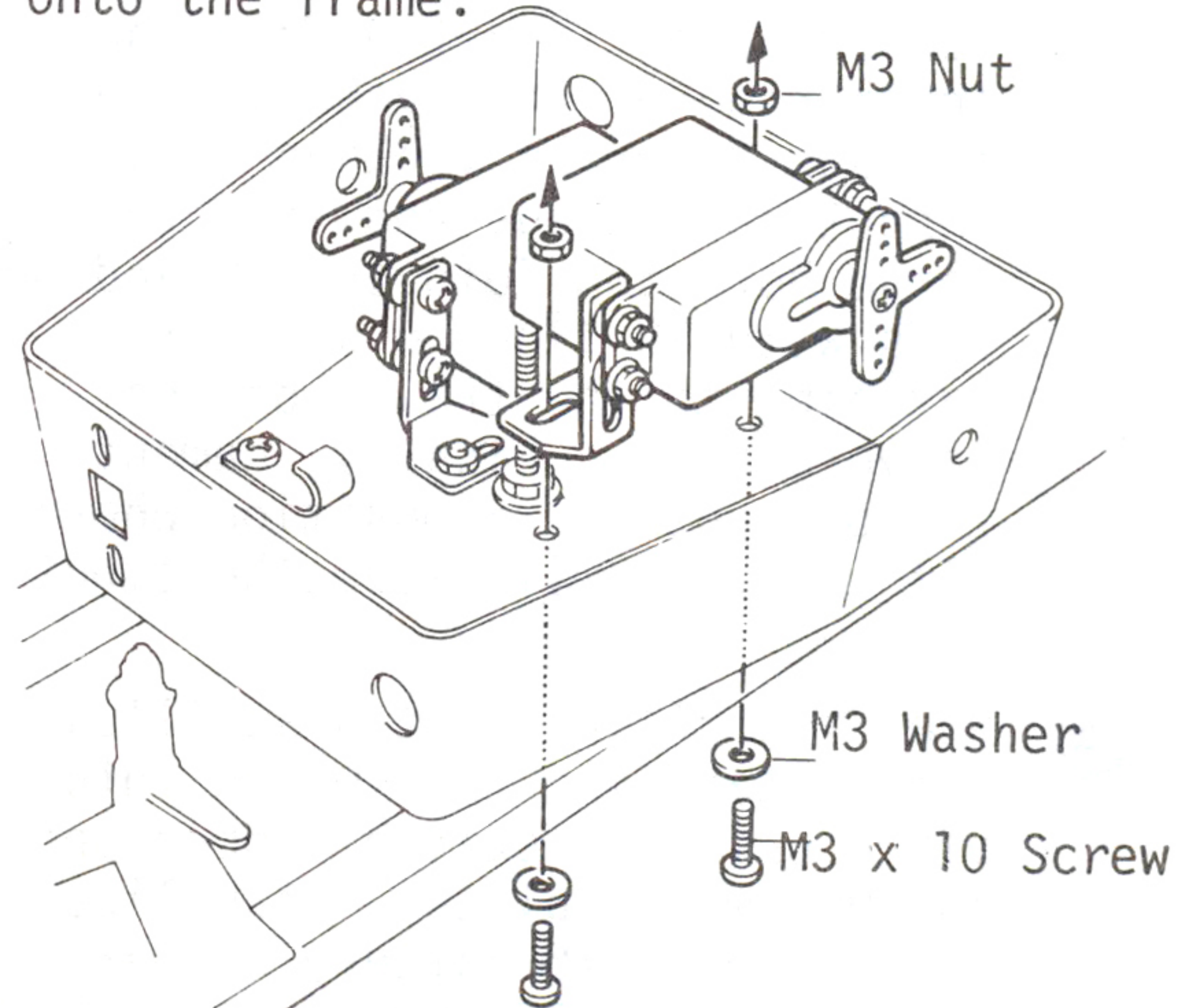
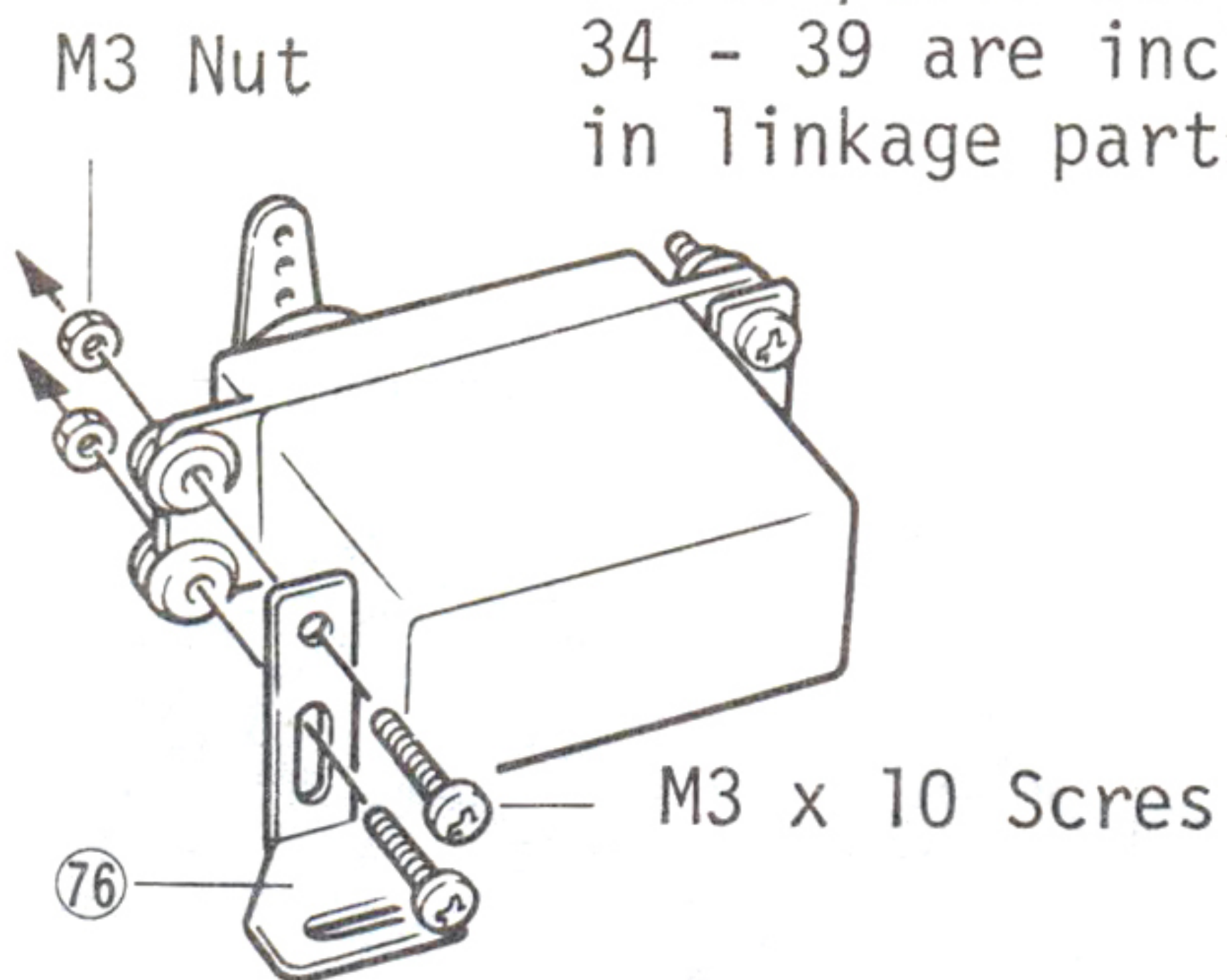

35 Servo bracket 76 is installed onto the steering as well as to the throttle control servos.

36 Servo is installed into the mechanism box but if the holes on the servo being used should not align, make a new hole with an awl.

37

First, cement rod rubber boots 74, have it inserted through the steering rod 77 as illustrated, install steering rod 77 with keeper 25 onto the servo saver, insert linkage rod 78 into the servo horn, stabilize the 77 and 78 rods with linkage stopper. When doing this process have the front tire and servo horn in the neutral position. Also, when removing and installing servo horn, there is a hole to fit screw driver in on the side of the mechanism box for convenience sake. After this process has been completed, insert mechanism box rubber cap 111 and close the lid. After the linkage has been completed, rod rubber boots is cemented onto the mechanism box but cement after finding the place where the 77 rod will move the smoothest.

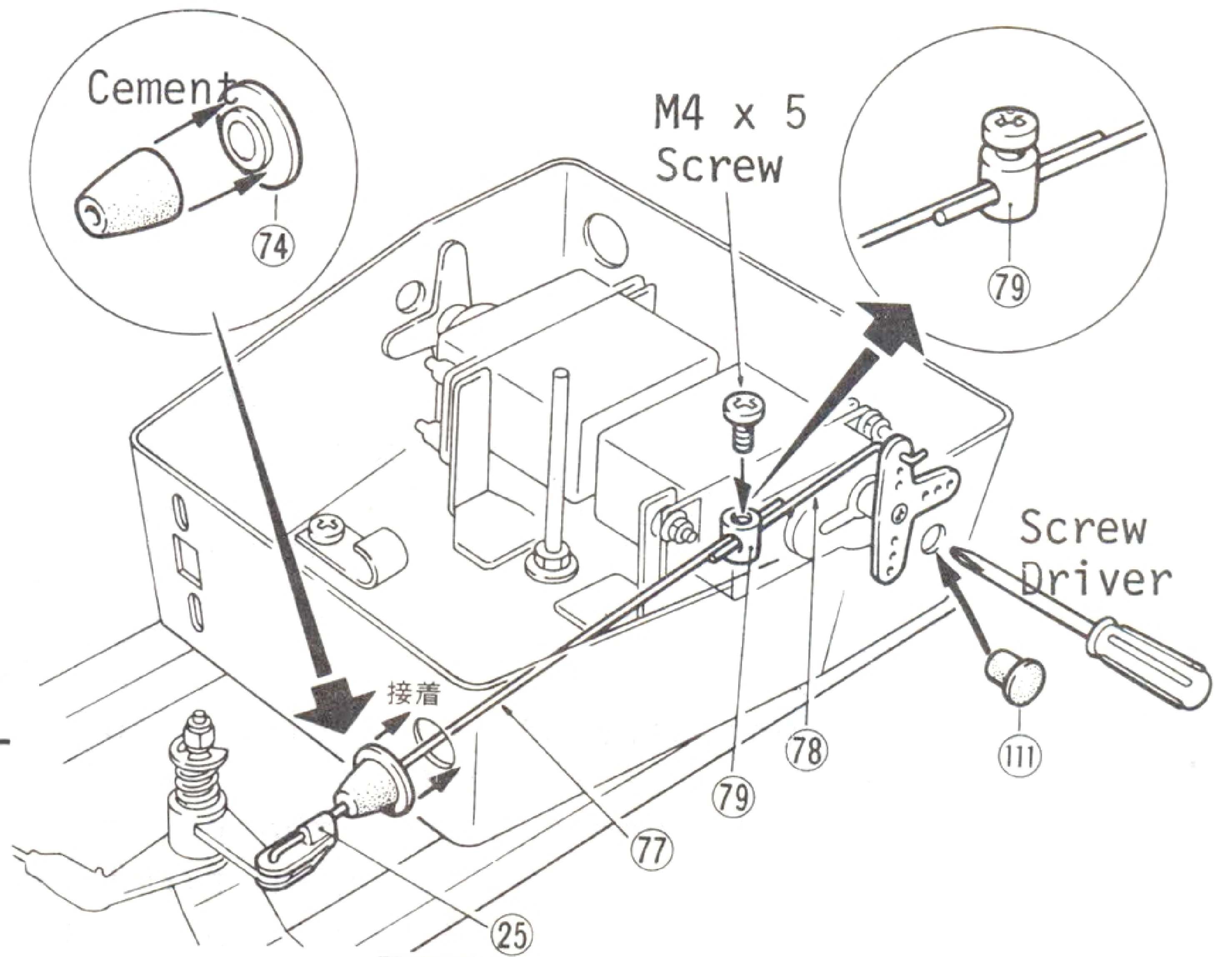

M3 x 5 Screw

Cement to inner side of mechanism box.

38

First, have the rod rubber bushing 74 cemented. Next insert 82 nylon collar into the 80 brake linkage rod on the "L" shaped bent side, then insert through 40 "L" crank as illustrated, and by fitting in 83 throttle control rod stopper a stabilize the rod 80 with the 84 throttle control rod stopper B. Next, insert 81 throttle control rod with the side bent in crank shape into the throttle lever and the other end into the upper side hole of 83 throttle control rod stopper "A" and stabilize the 81 throttle control rod with M3 x 5 screw. Next, have the 74 rod rubber boots inserted from the inner side of the mechanism box through 80 brake linkage rod, insert 78 linkage rod into the servo horn and join the 78 and 80 rods with 79 linkage stopper matching to the travel of the servo stroke. Finally, cement 74 rod boots in a position where all the rods will move the smoothest.

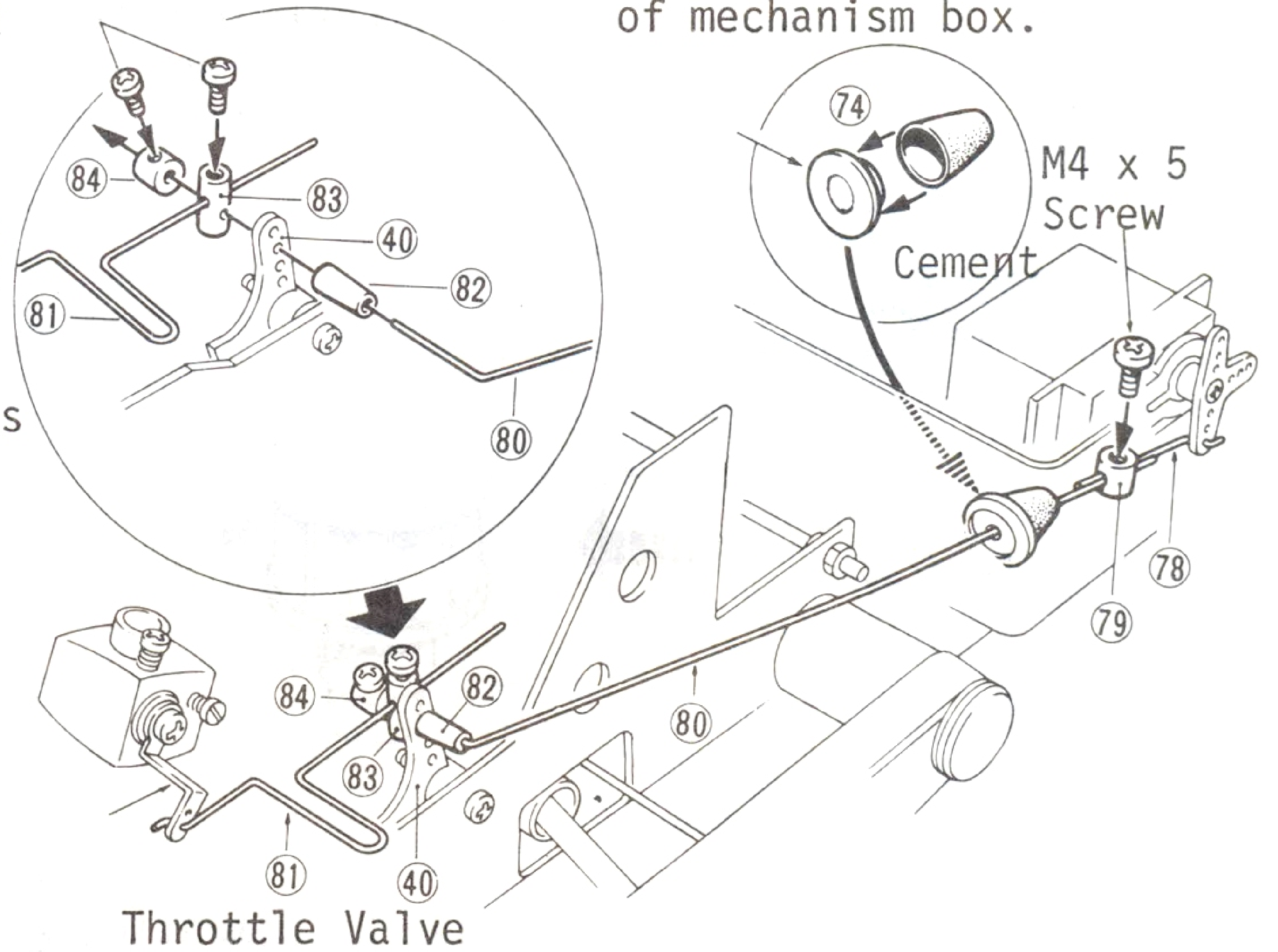

Throttle Valve

39

When installing switch as illustrated. Stabilize the switch into place using 73 switch rubber boots and 90 switch plate. Stabilize battery onto 75 battery holder hardware with 85 rubber band. The receiver is placed on top of the servo. Install 86 antenna guide onto the mechanism box as illustrated.

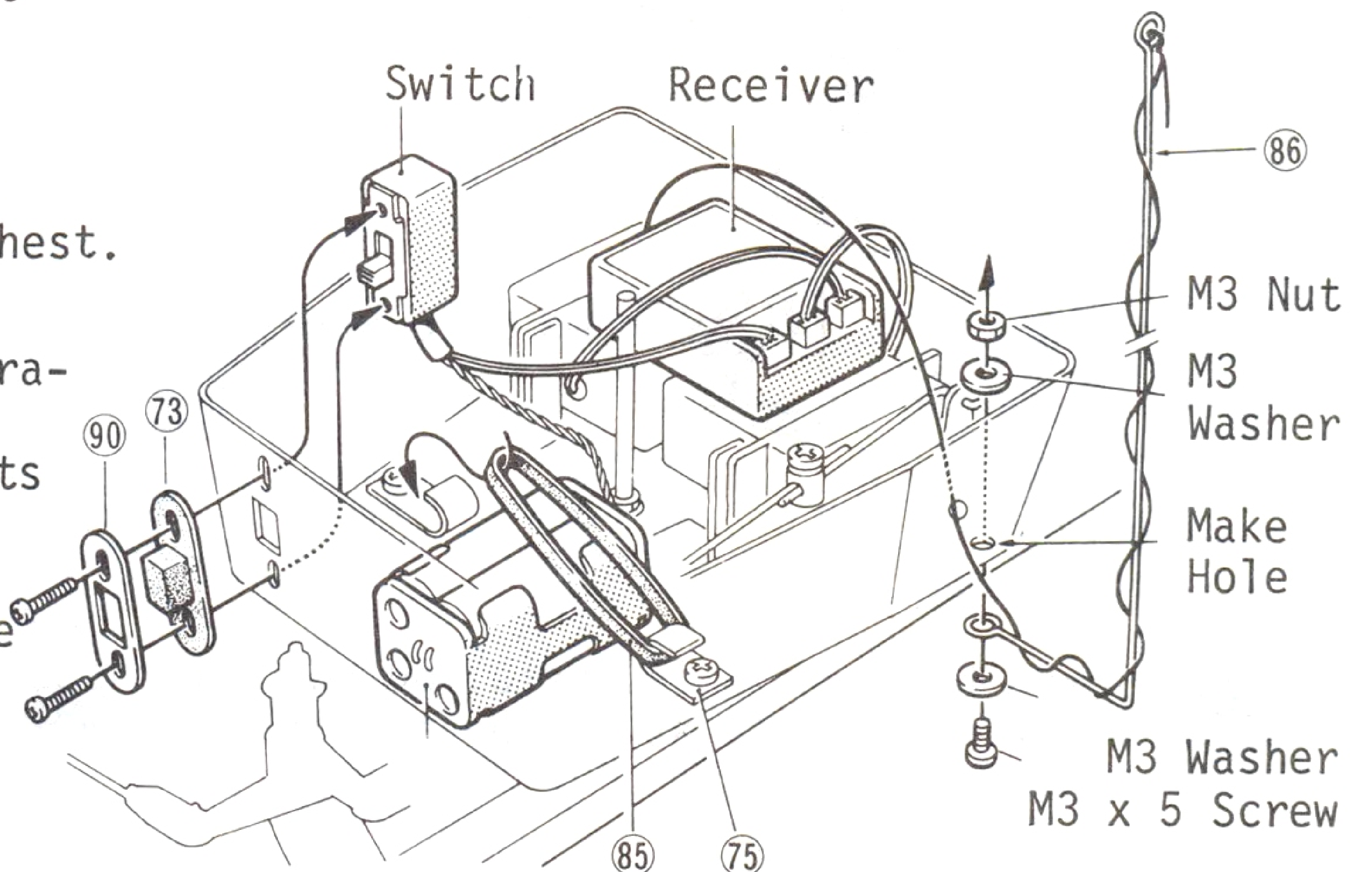

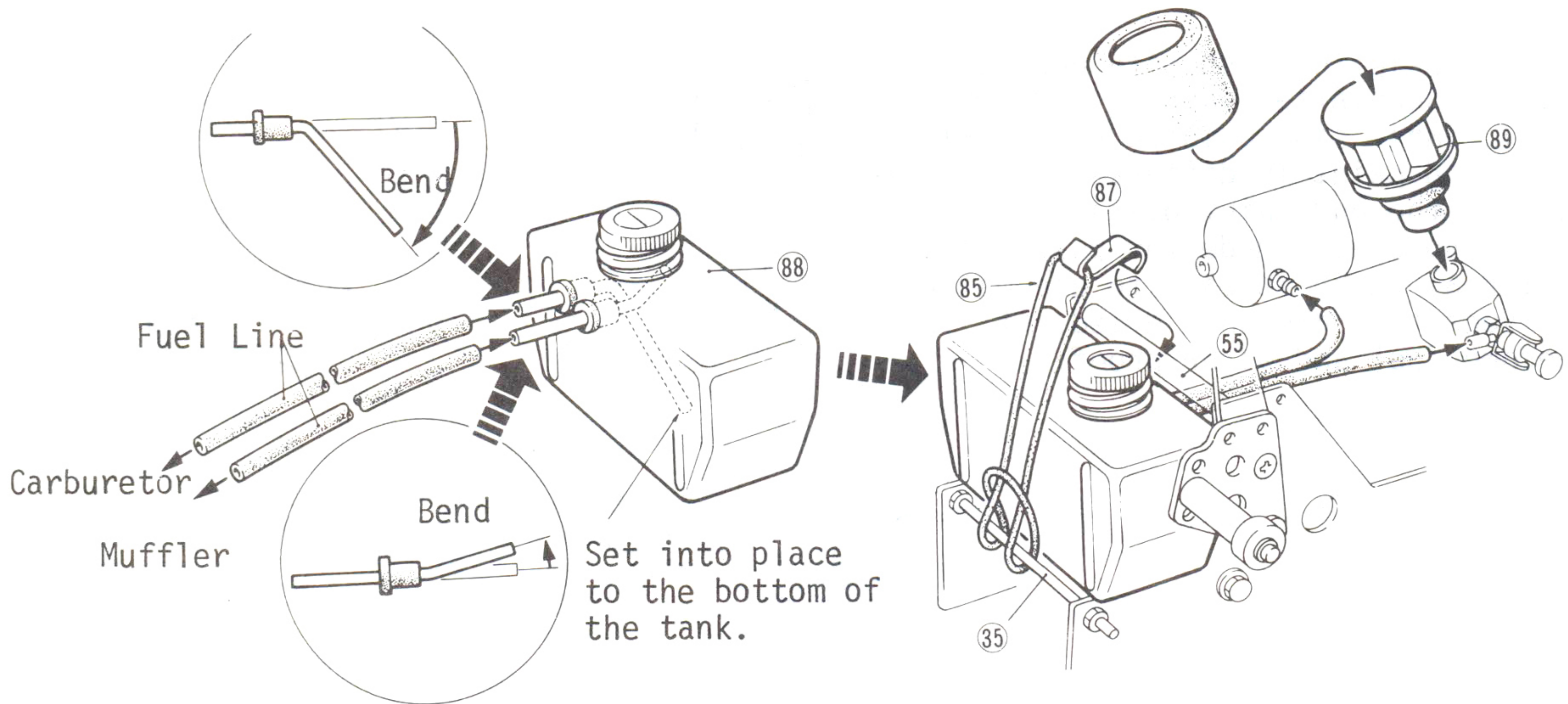

- 40** Assemble fuel tank as illustrated. For installation, hook rubber band 85 onto stud bolt 35 and stabilize into place by hooking the 87 tank installation hardware onto the upper stud bolt 35. Install the 89 air filter assembled in step 32 onto the carburetor.

- 41** Cement radio box cover cap 116 and radio box seal 114 with rubber type cement.

Note: Small parts for step 41 - 48 included in the radio box parts bag.

Cement 114 onto inside of 92.

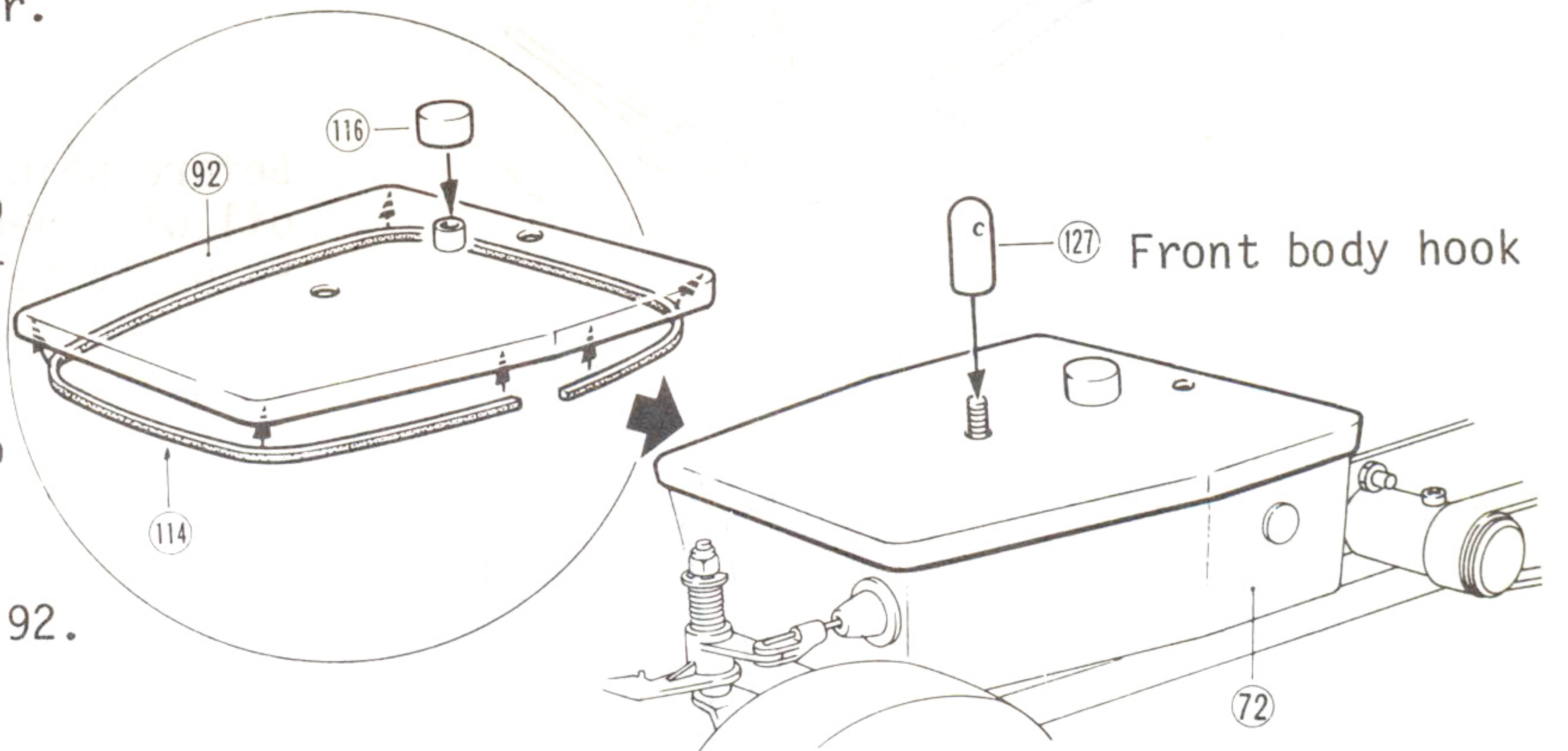

42

Install gear box guard 57 into the joint collar 41 as illustrated.

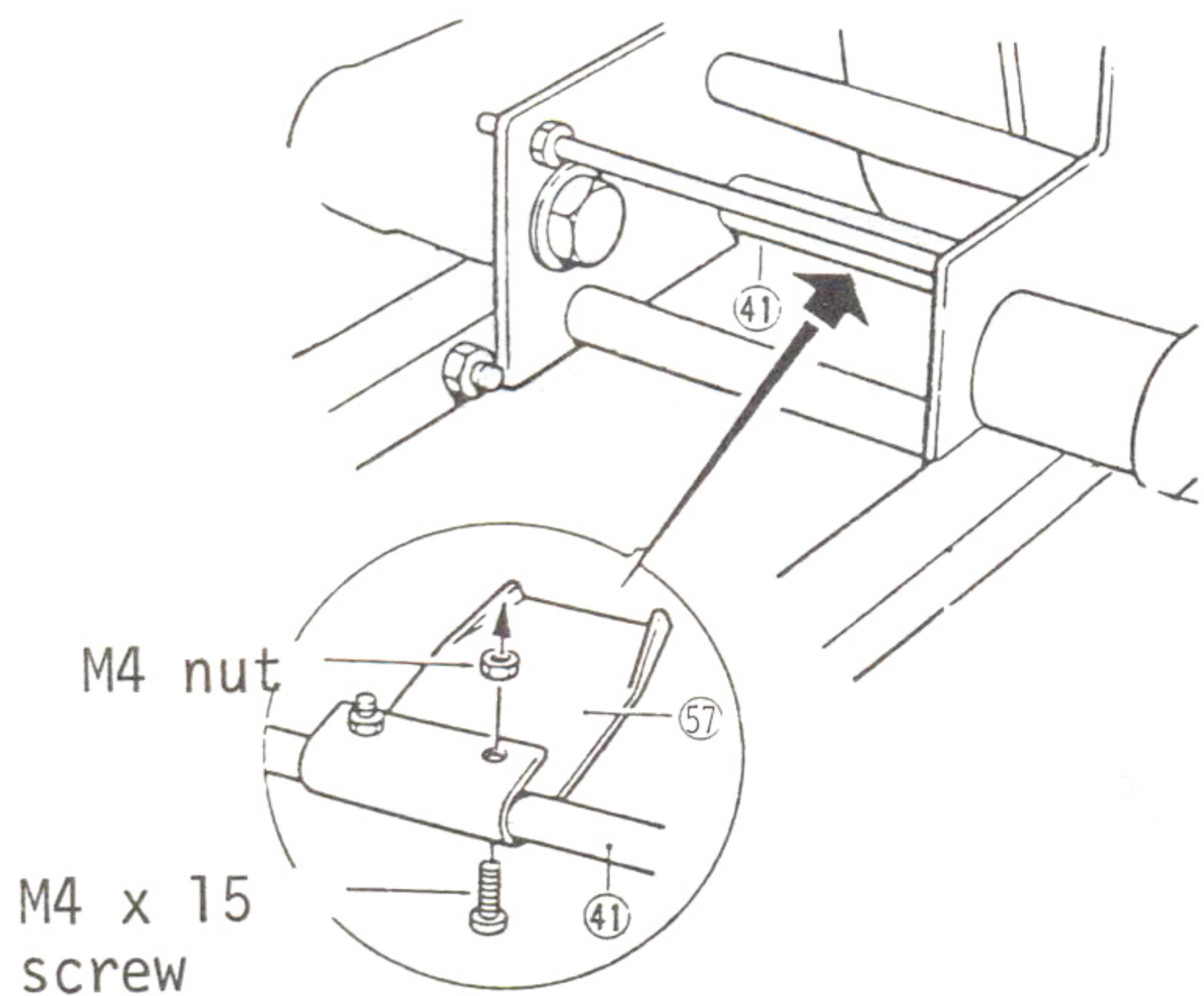

43

Cut the body 93 with a scissors or knife along to the cutting line and make driver guard holes 57 with an awl.

Make 3mm hole with awl.

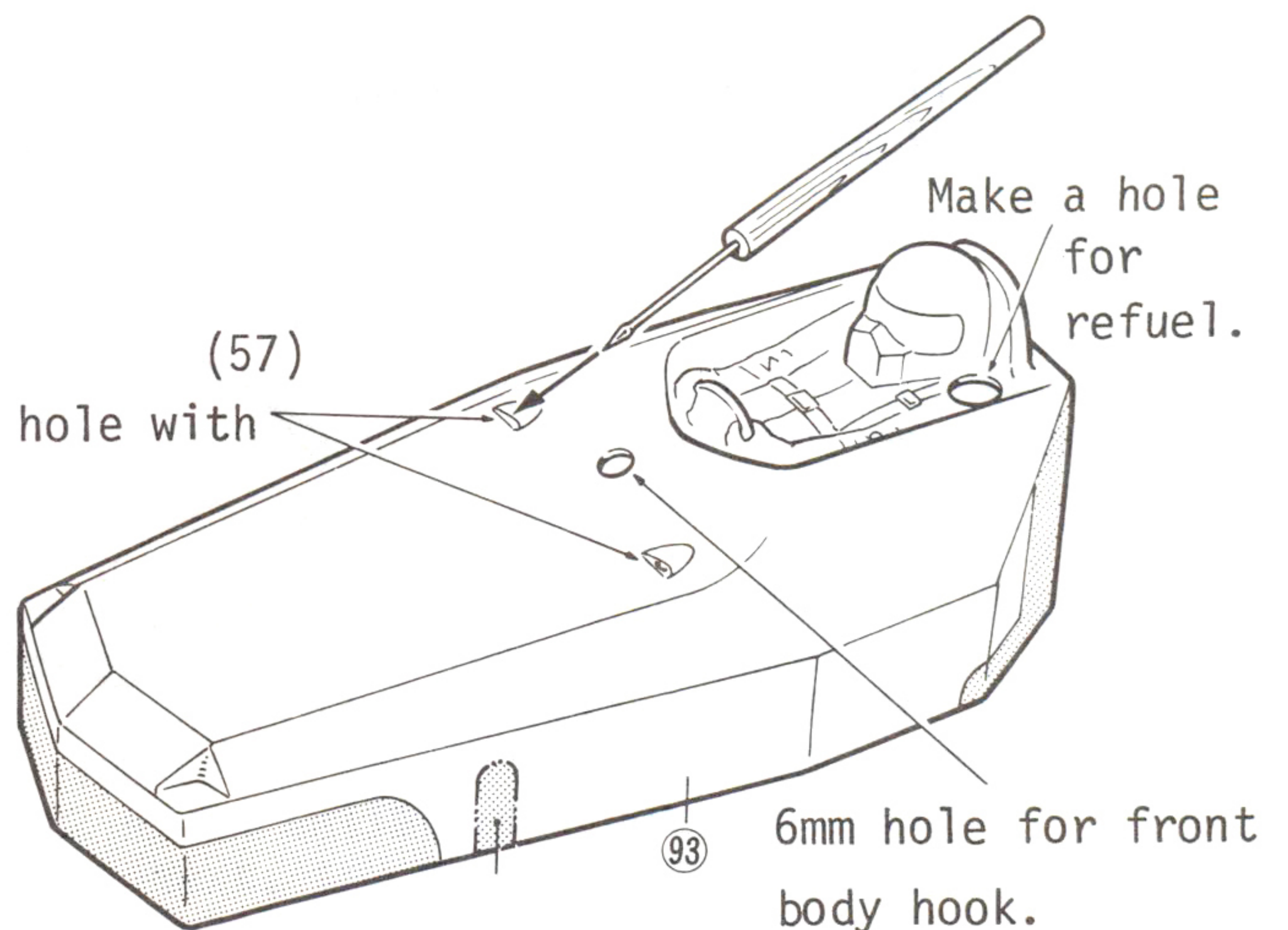

Cut off the shaded portion in case install the oil damper.

44

Before painting wash with neutral liquid soap. After washing and dry well, inner side painted use masking tape and paint in different colors and at the end paint overall. Use paint specially made for polycarbonate material which is easy to use water solvent type and once dried, it become fuel and water proof.

Polyca Color Paint

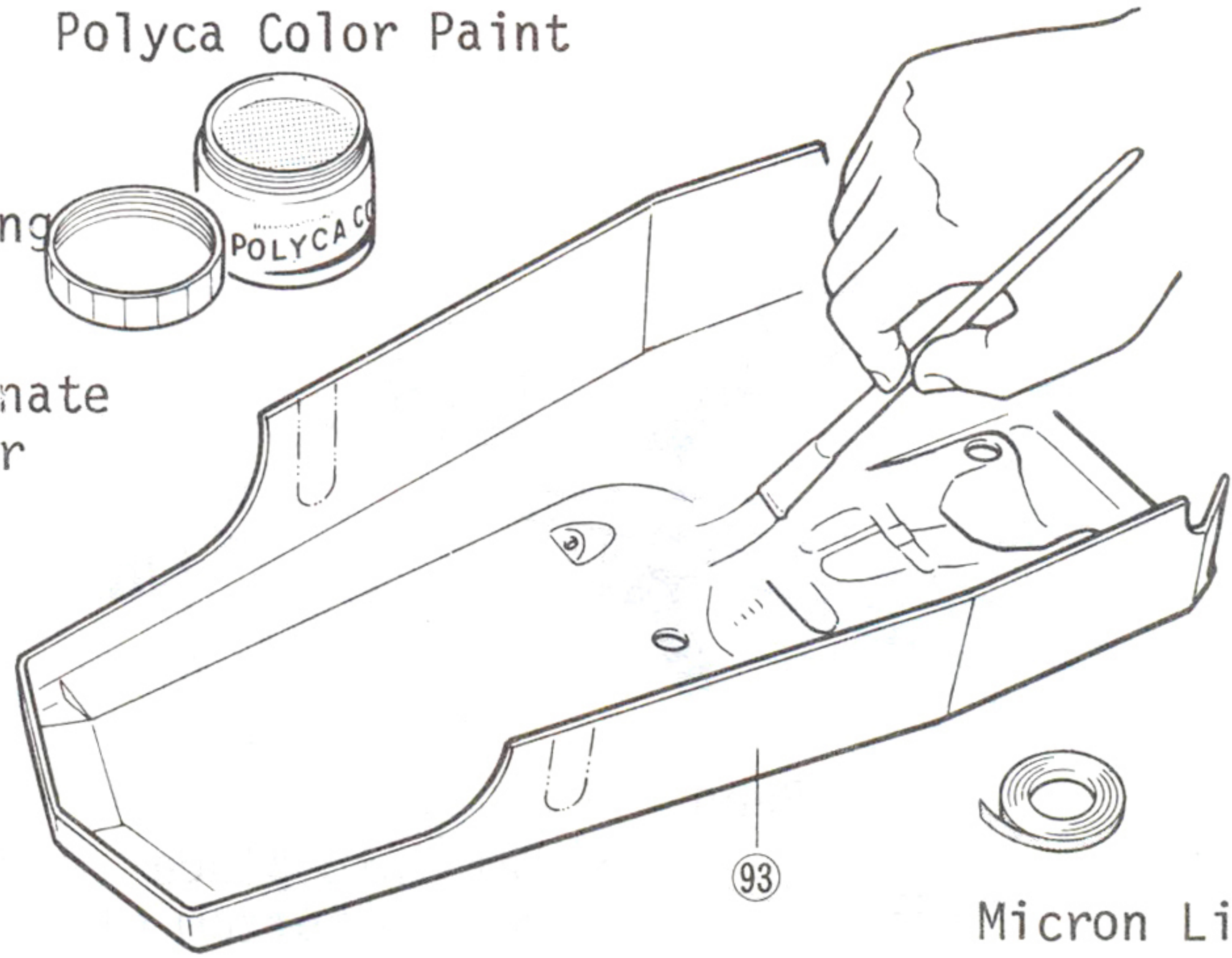

Micron Line Tape

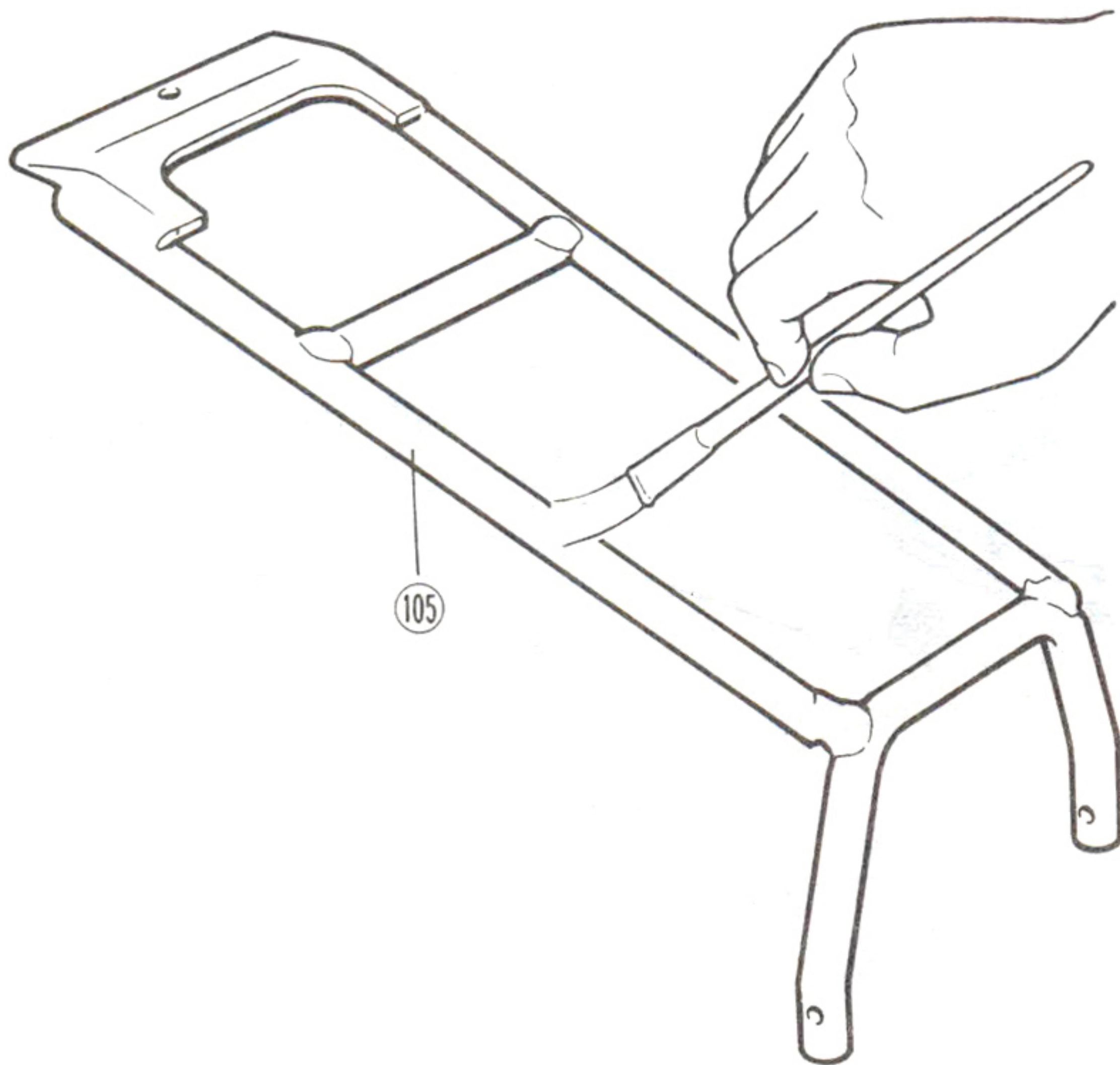

45

Before painting, wash away dirt and oil with neutral liquid soap. Paint to be used should be for vivyl type and fuel proof. (Engine color, etc.)

46

Install driver guard 129 onto the body 93 as illustrated.

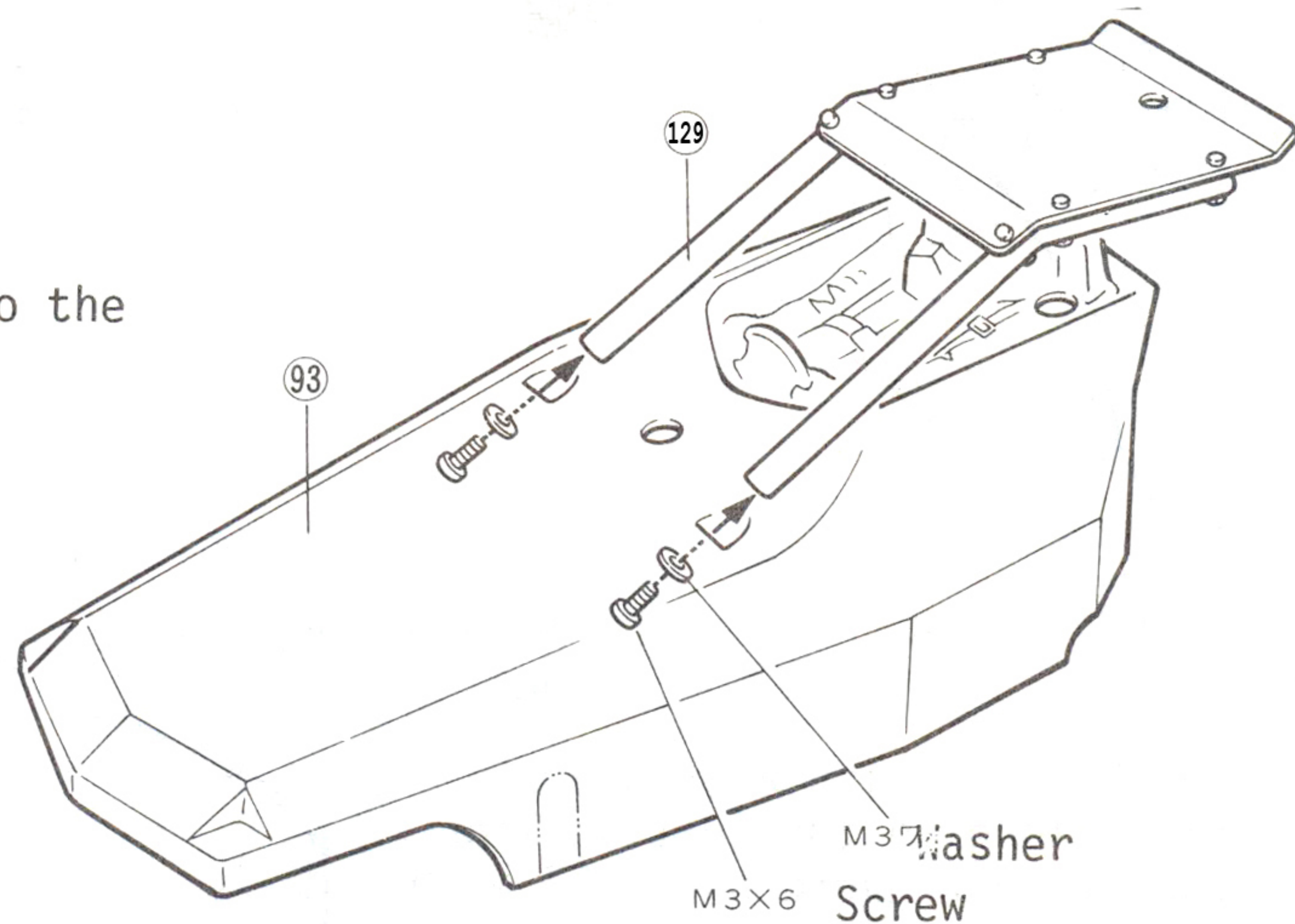

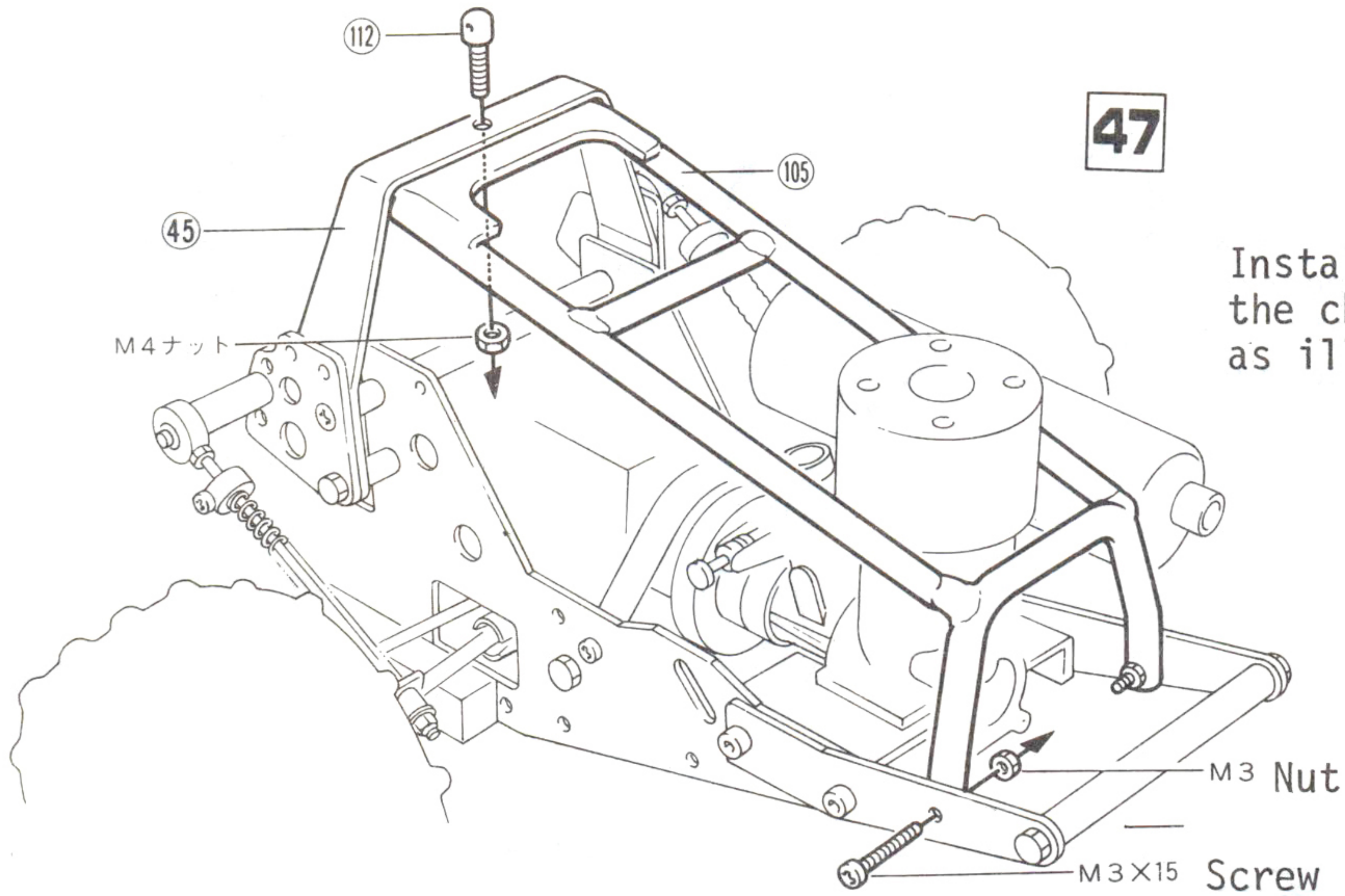

47

Install 105 rear guard onto the chassis with screws and nuts as illustrated.

48

Body 93 is installed onto the chassis and hold firmly with a body hook pin 113 as illustrated.

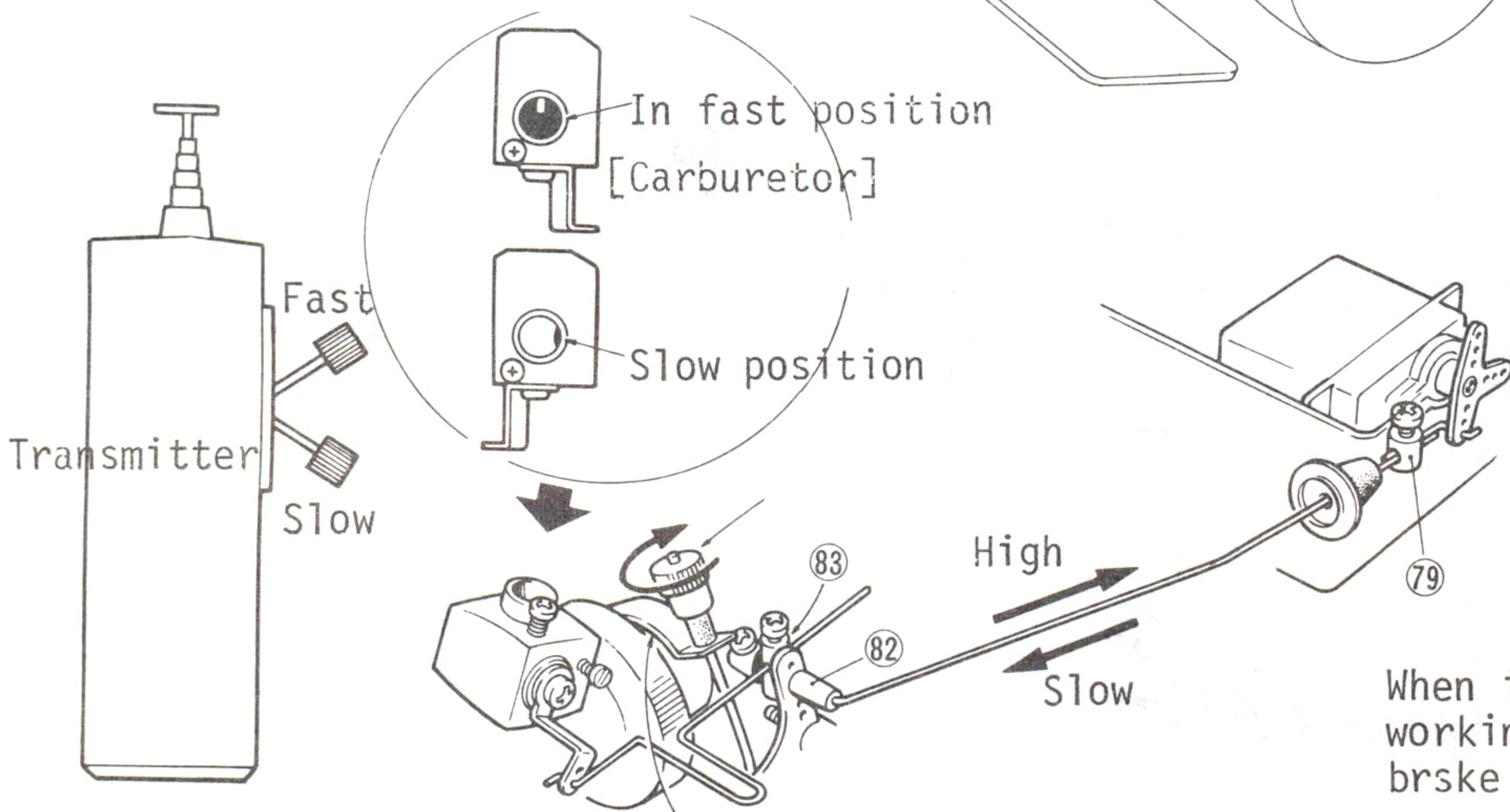
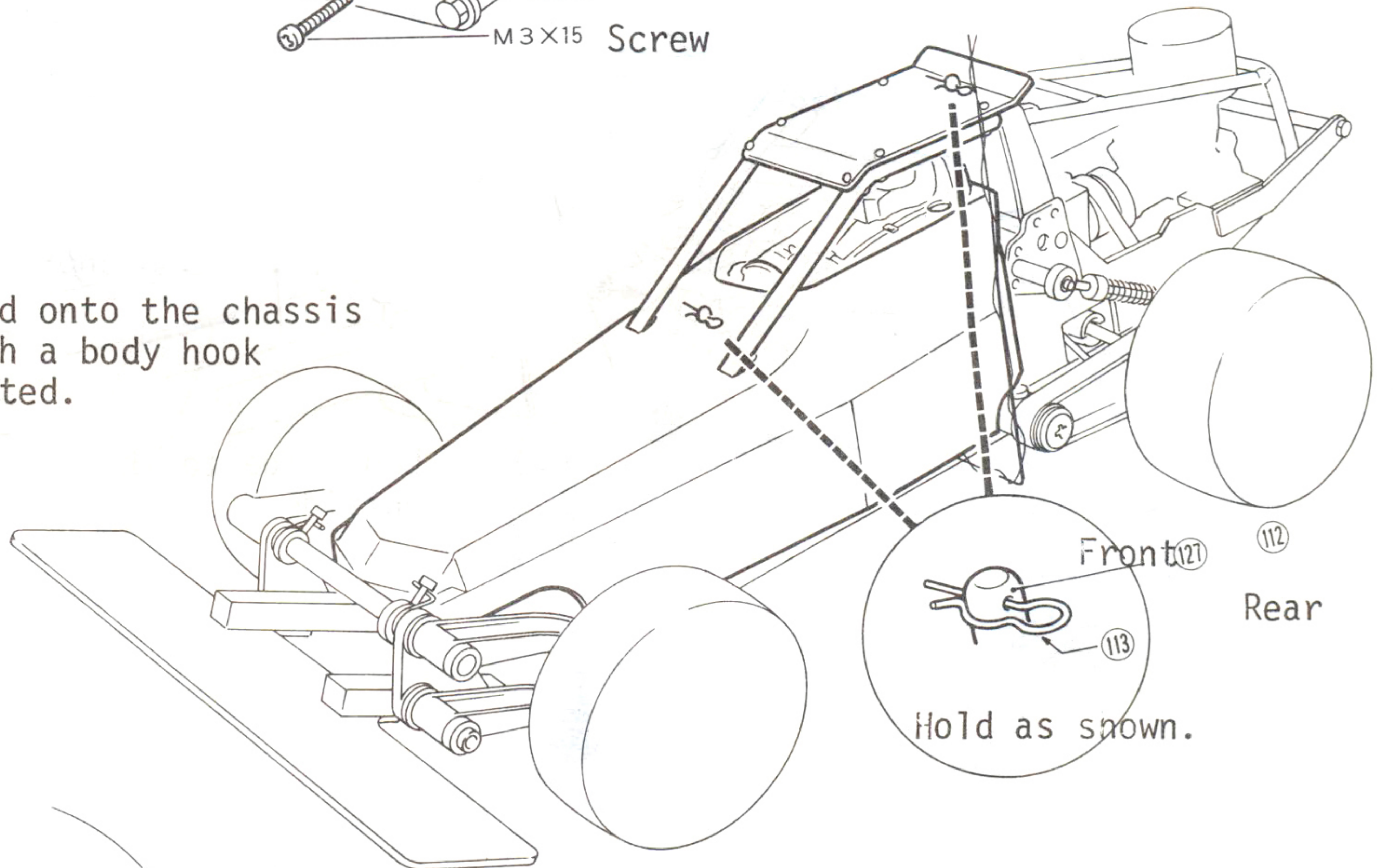

[Brake adjustment]

When turned to the right it tightens and loosen when turned to the left.

When in slow position brake in working and in fast position brske is released.

49

Before running, radio control system movement should be tested and have the brake, throttle control etc. adjusted. Adjust so that when the transmitter throttle control stick is in the slow position the brake is in the working condition with the carburetor in the slowest position by loosening the 79 and 83 stopper and by moving the rod. Also, be careful so that 82 nylon collar will not hit against the rear frame when in the slowest position. Next, try moving the steering stick and adjust so that the front tire will turn lightly.

50

The adjustment of the rear spring 51 becomes weak when the 44 3φ stopper is moved down and when move up, the rear suspension becomes strong. For the front, right side becomes weak and left side strong.

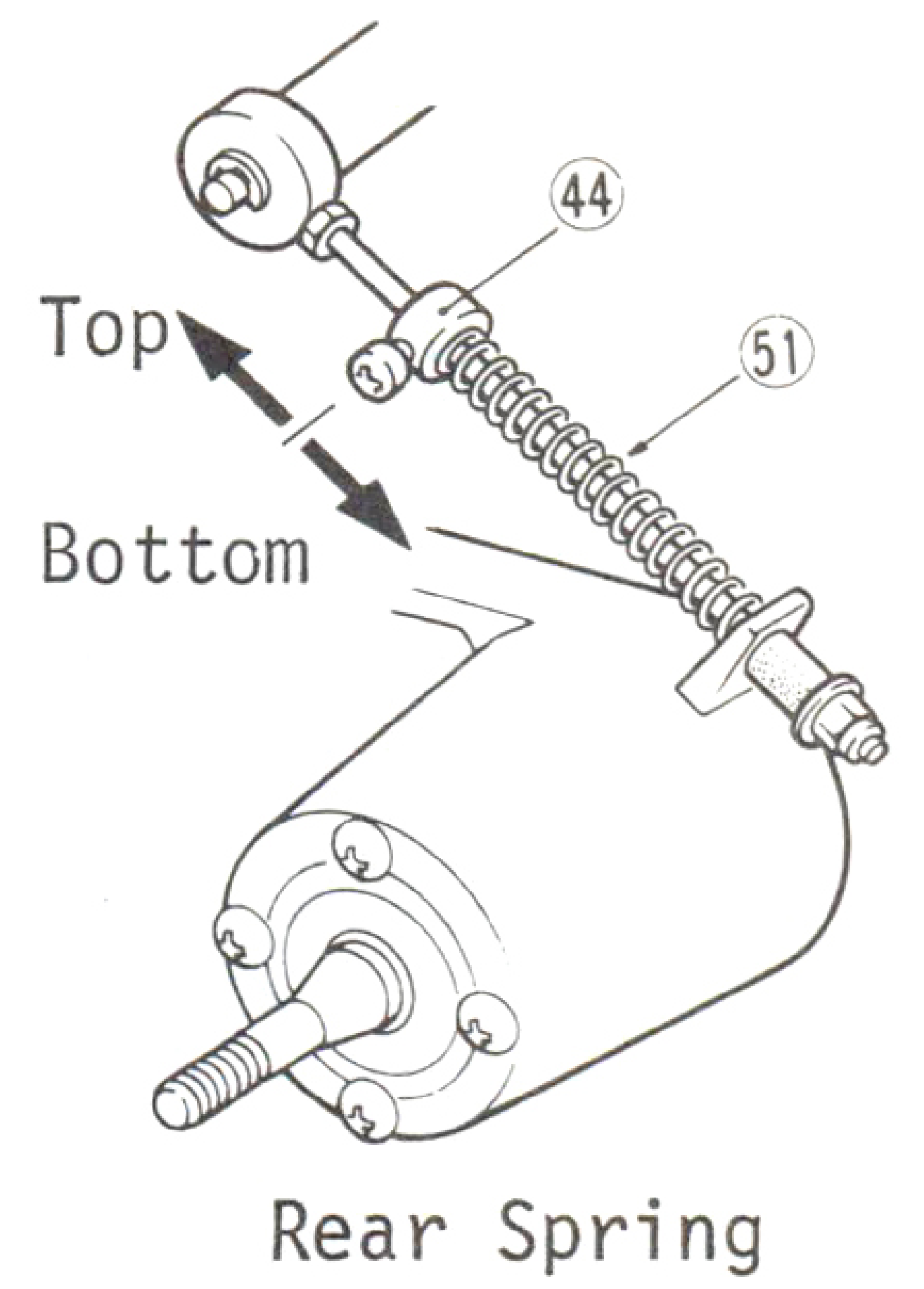
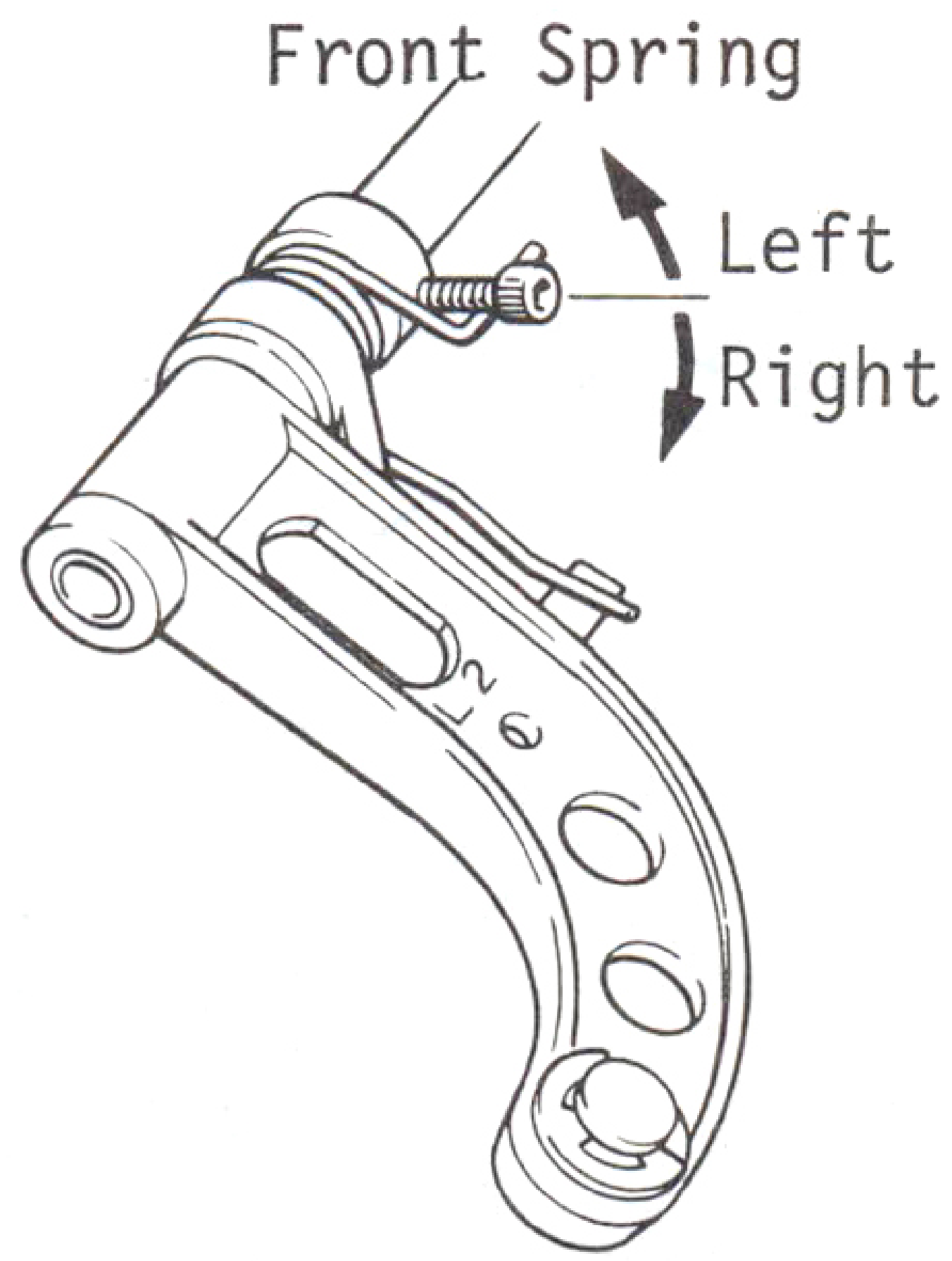

OPTION PARTS

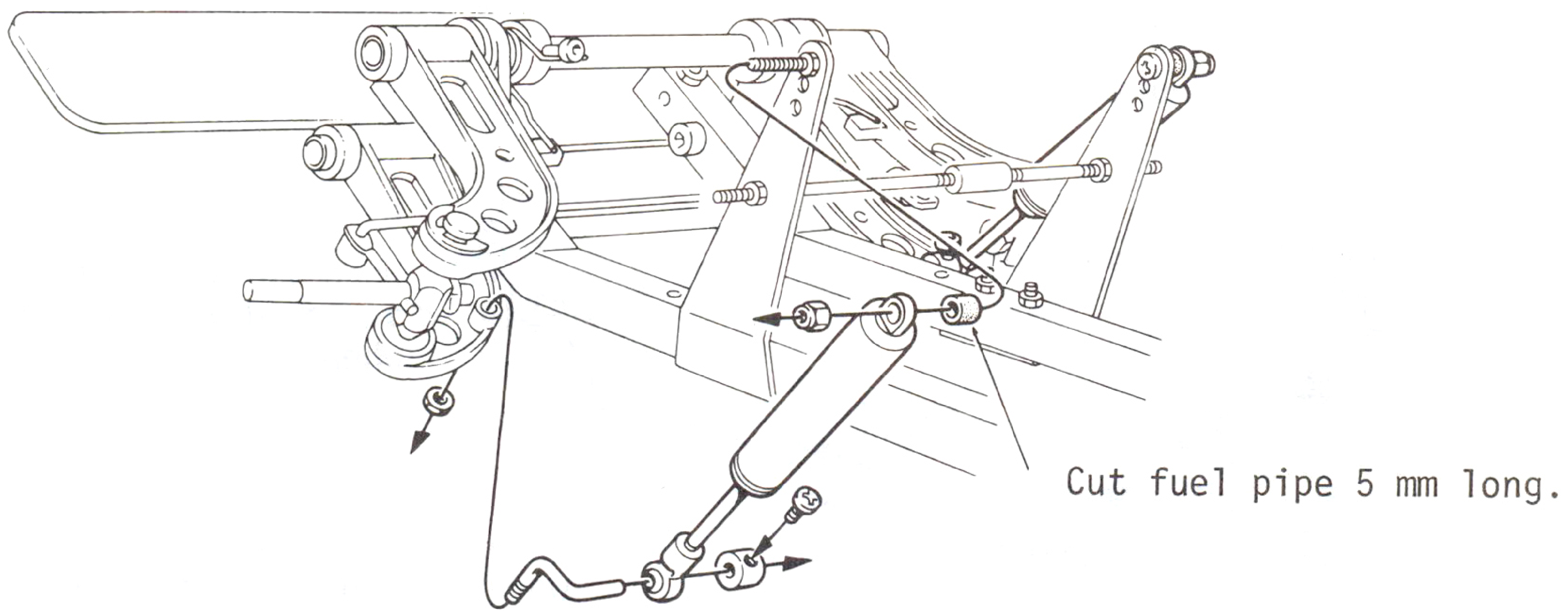
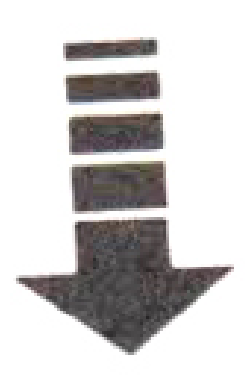
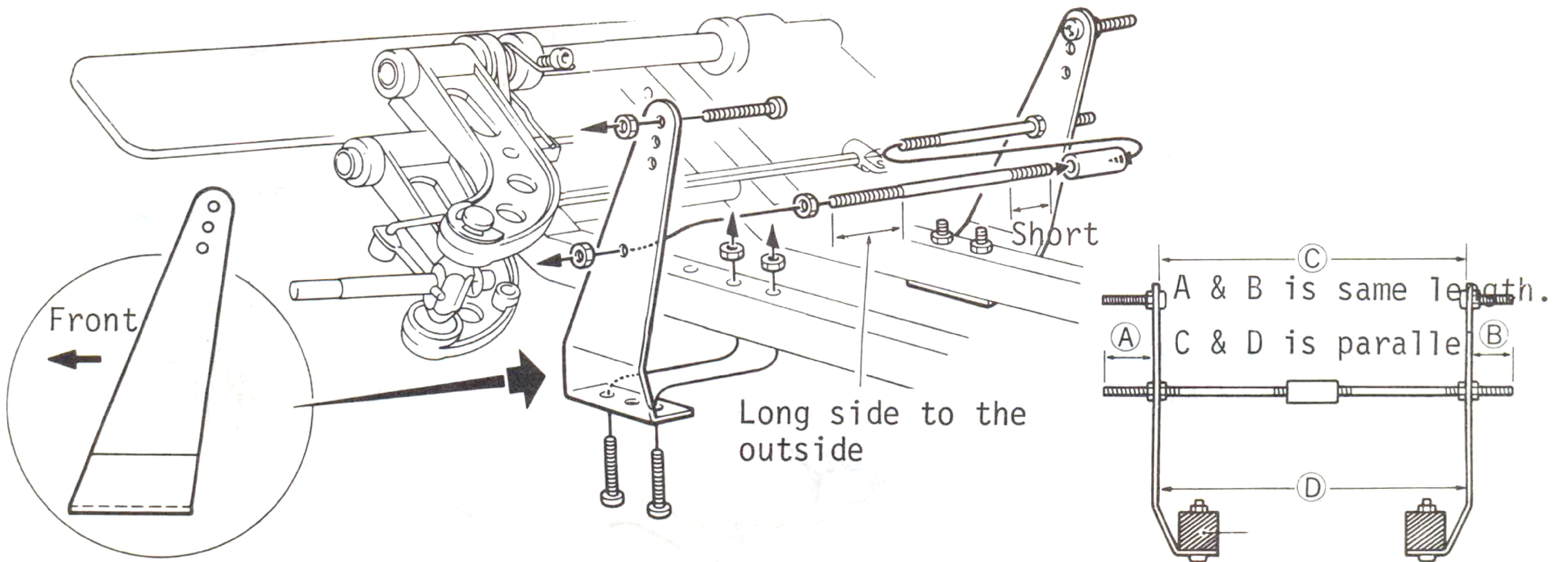

51

The method of installing optional front damper (CB-88). Hardwares for installation is included in the oil damper.

OPTION PARTS

Left

Assemble right side in the same manner.

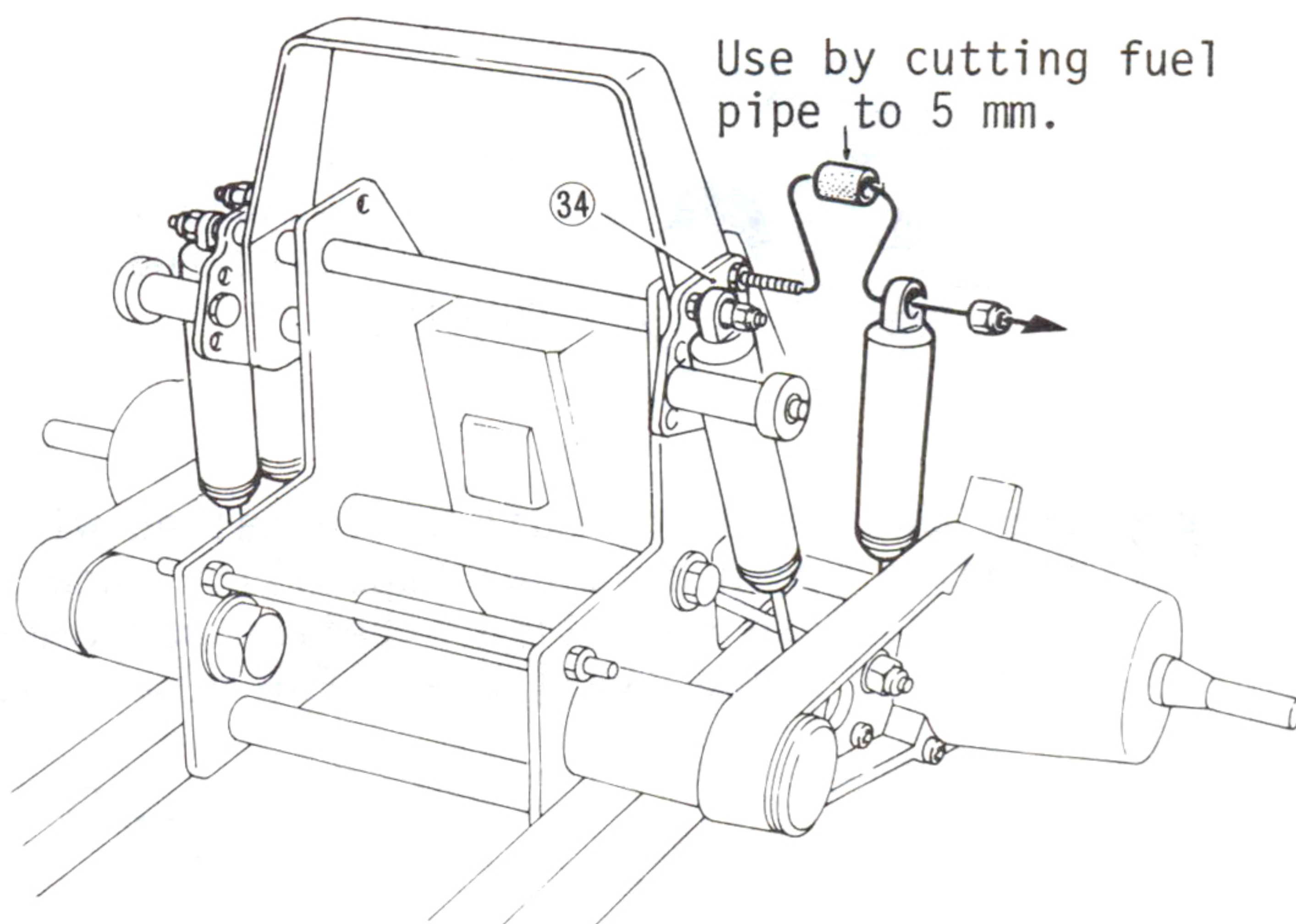
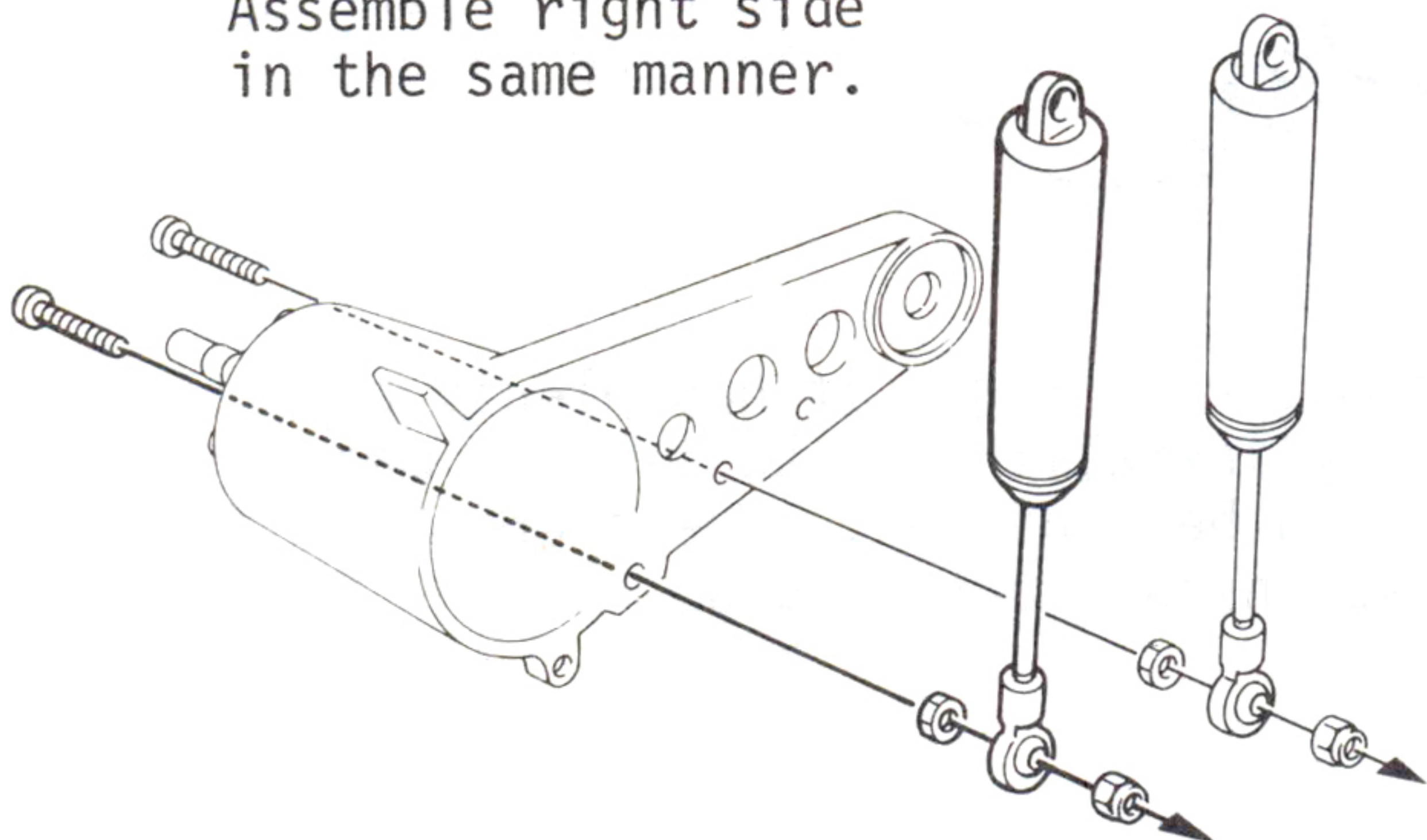

52 Two rear dampers (optional parts #CB-89) can usually be employed, but another way of characterizing the model is to install four of them.

53 The upper part of the dampers can be fixed to the rear suspension plate 34 as shown in the drawing.

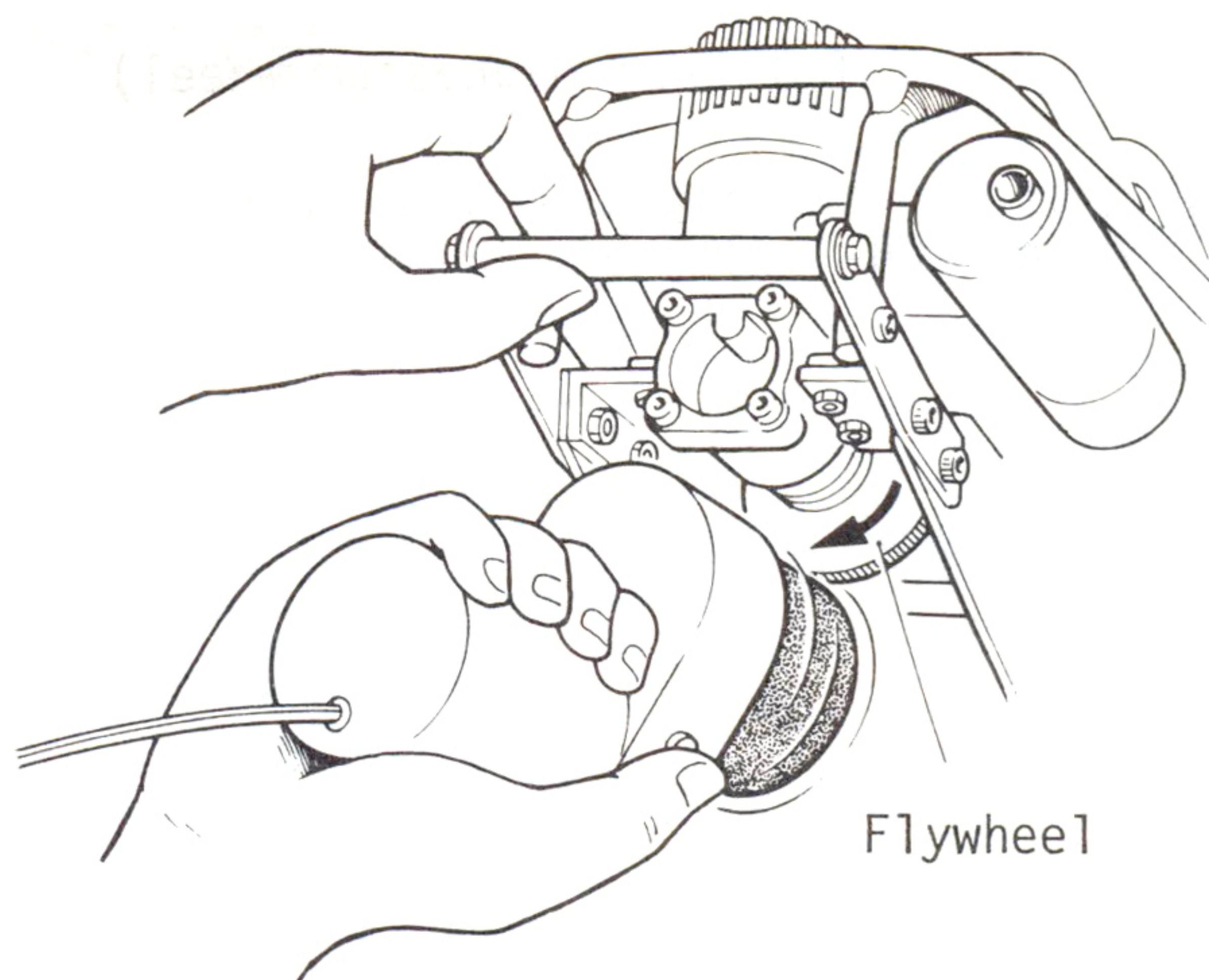
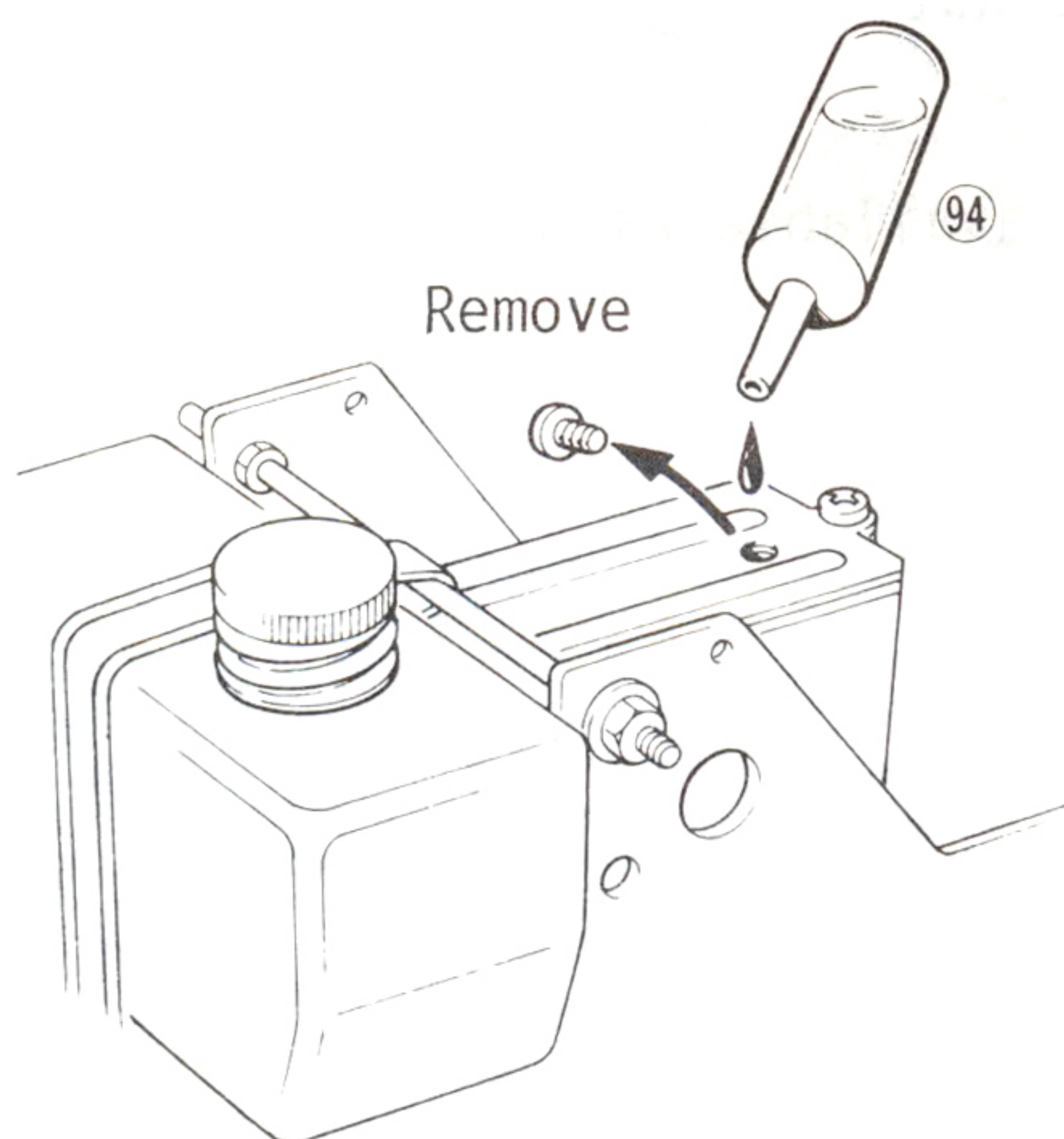

54 Remove the M4 screw on the lid of the gear box and through this hole, fill with 94 oil (5cc) which is included in kit.

55 The way to start the engine is to rotate by rubbing the electric starter against the flywheel from the bottom side of the chassis as illustrated. The rotating direction of the starter is to the left.

56 For adjusting the differential gear, remove the top of the gear case as illustrated. Tighten the M3 nylon nut which are binding the balls to increase the differential gear effect; for decreasing the effect loosen the nuts. (Note: when tightening or loosening the nuts, do it evenly little by little at a time in order to keep the plate parallel.

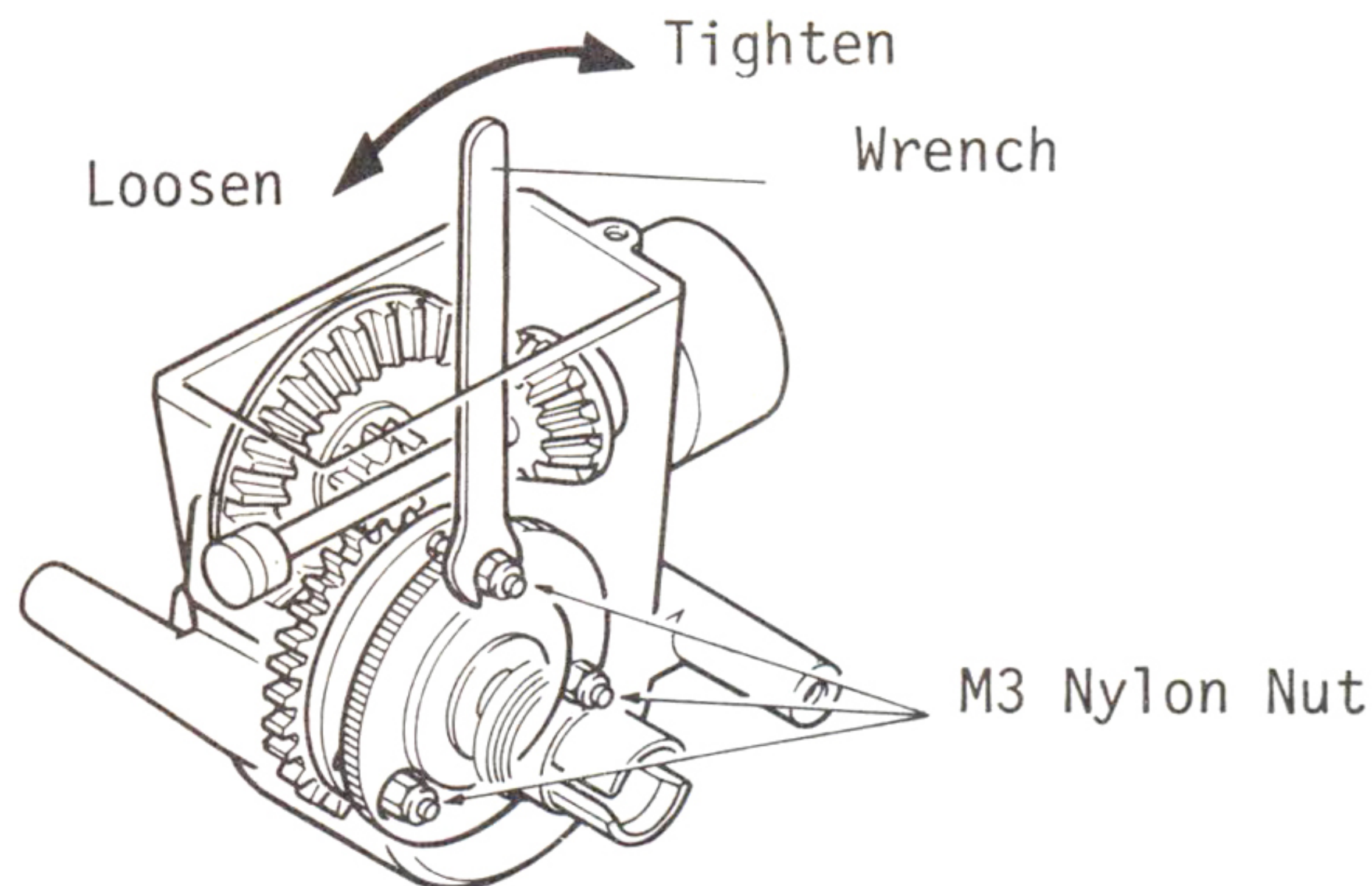

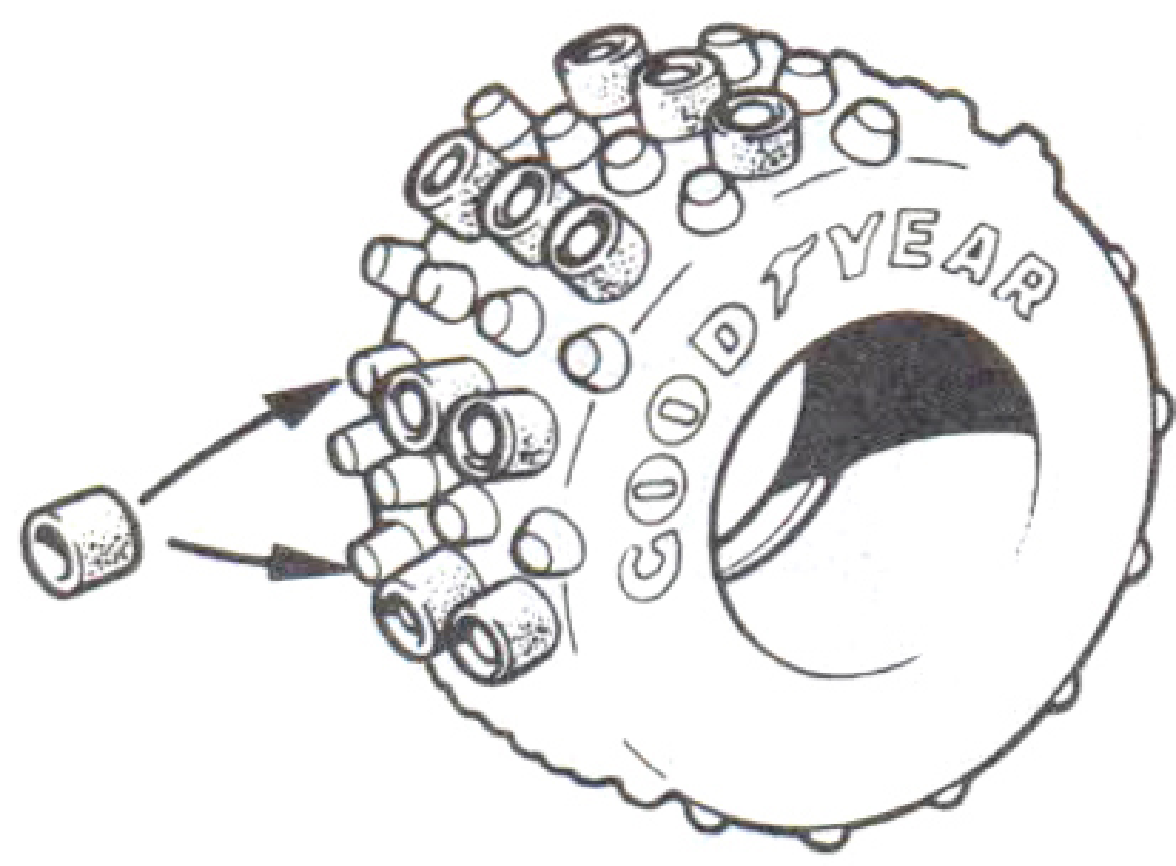

Nylon Super Spike
(Most suitable for
general dirt road
running.)

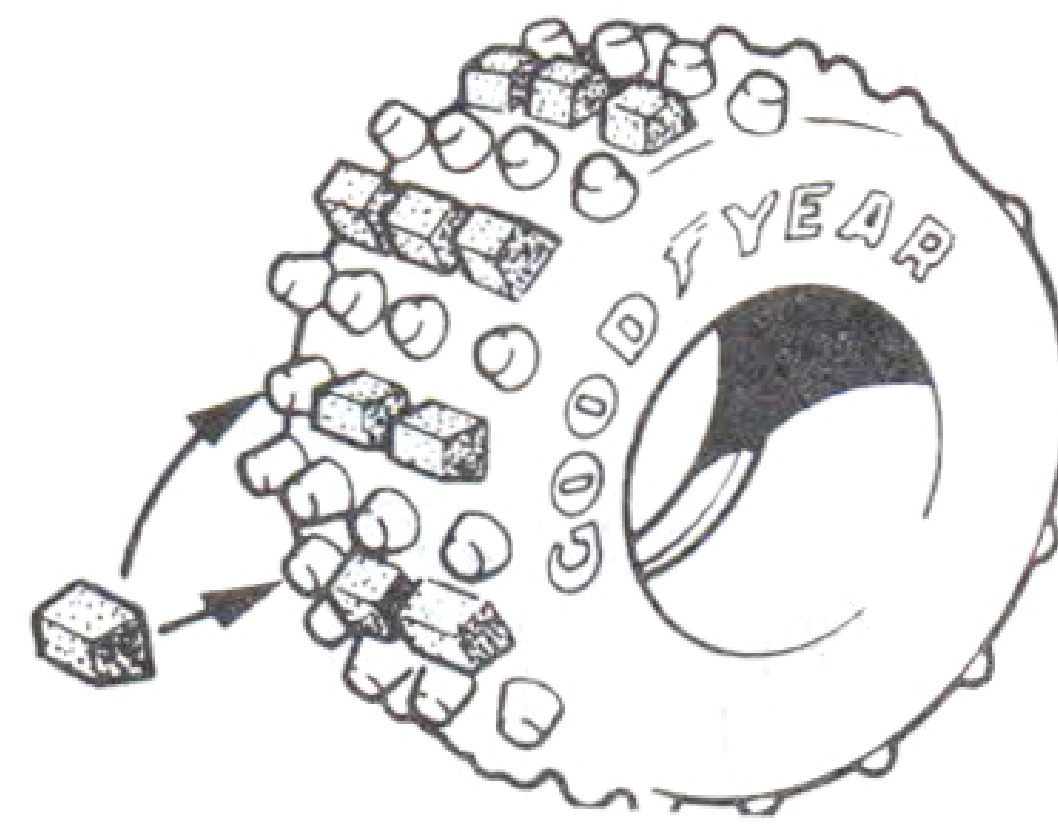

Super Spike
(Good for running
in deep sand.)

57 Even though the circuit is installed with normal rear tire, it has plenty of gripping (road holding) Capability, however, by installing spike tire to match with the road condition a better performance can be expected. There are 2 different spike available. For cementing, use instant drying glue.

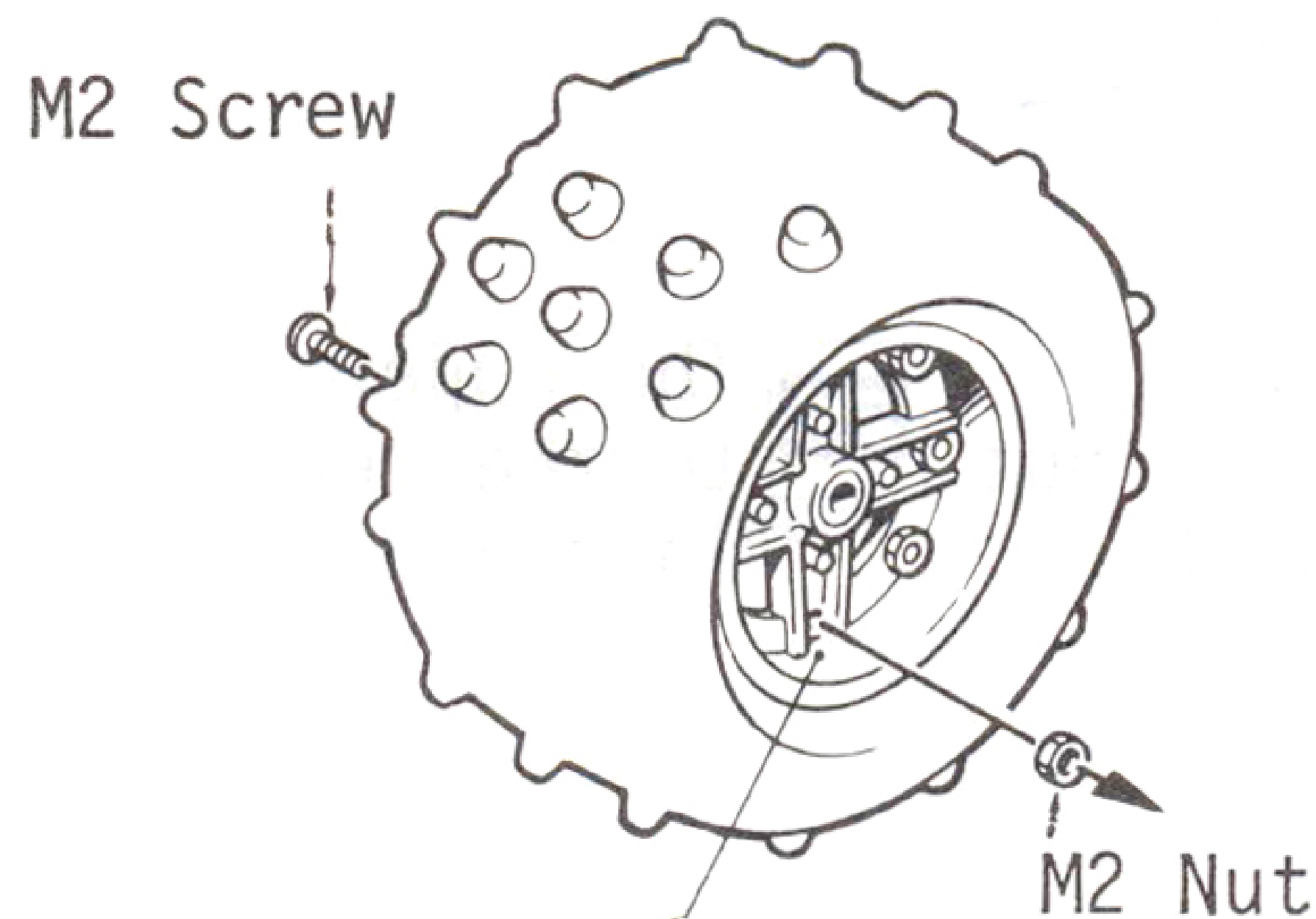

(Optional Magnesium wheel)

58 A strong and light-weight magnesium wheels are available as optional parts. Front (CB-102) rear (CB-103).

Optional wheel installation.

The optional wheels set were specially released for the new front and rear SAND SUPER tires. These tires offer superb grip which results in great handling characteristics.

Front Wheel CB166
Rear Wheel CB167

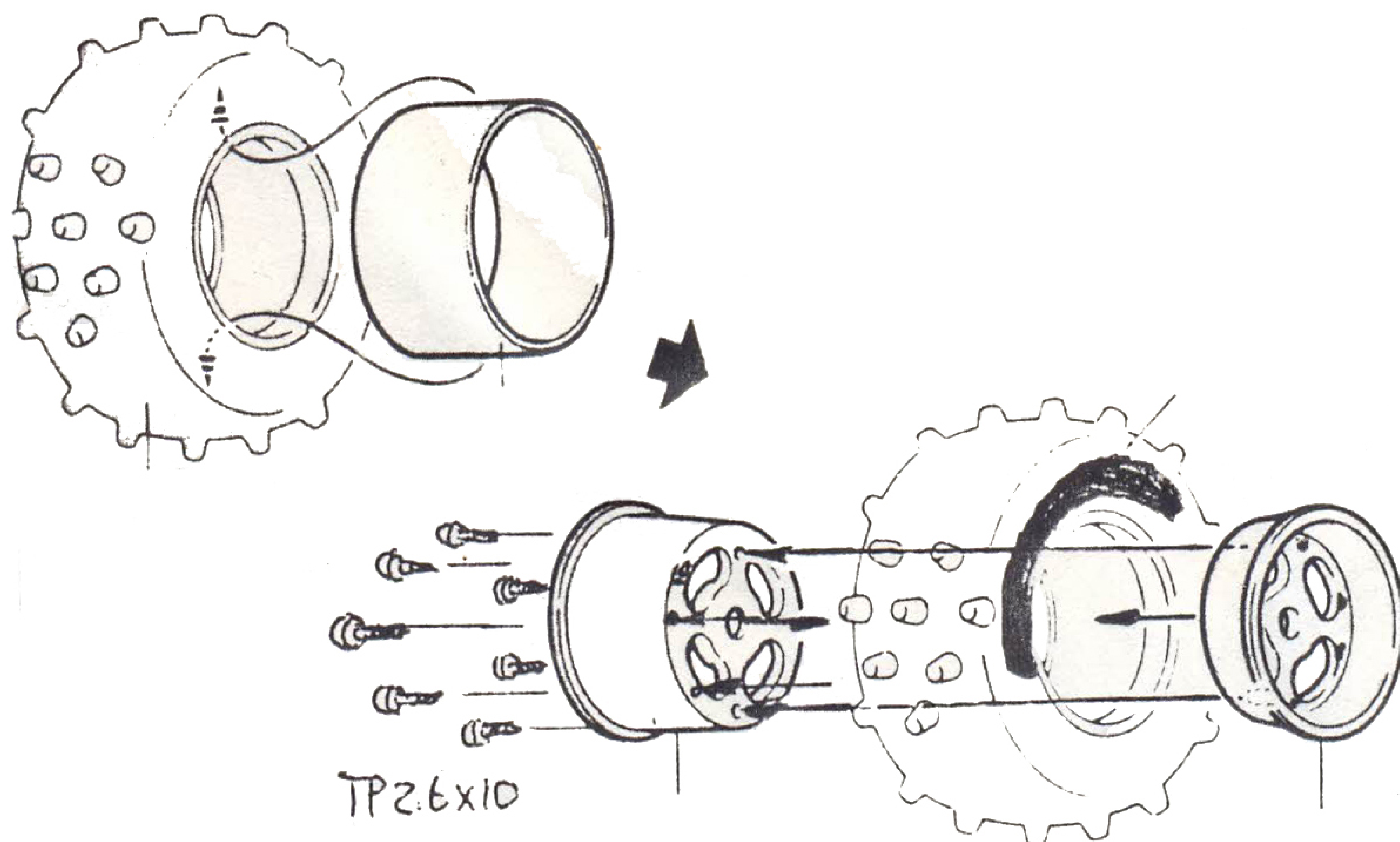

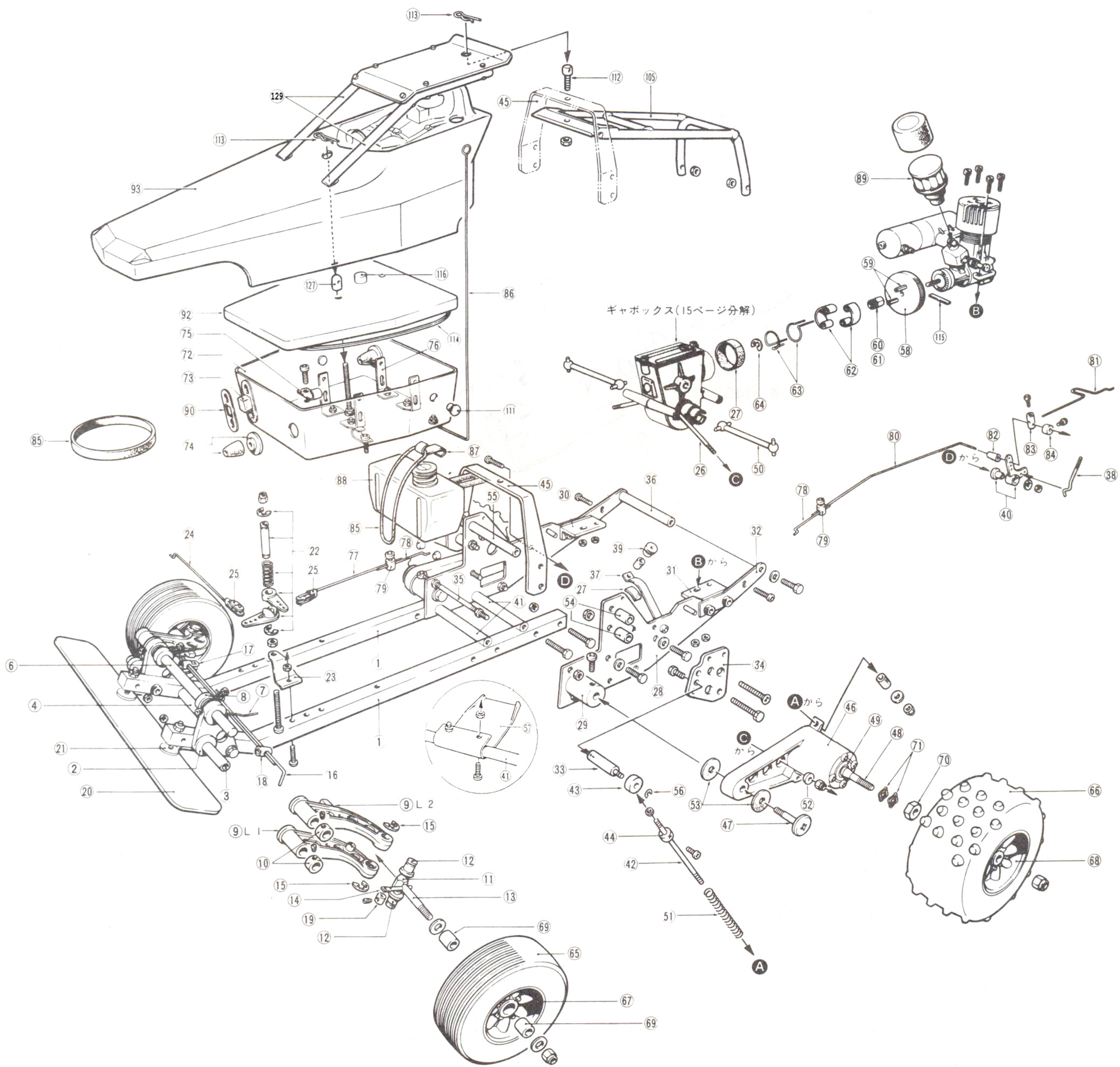

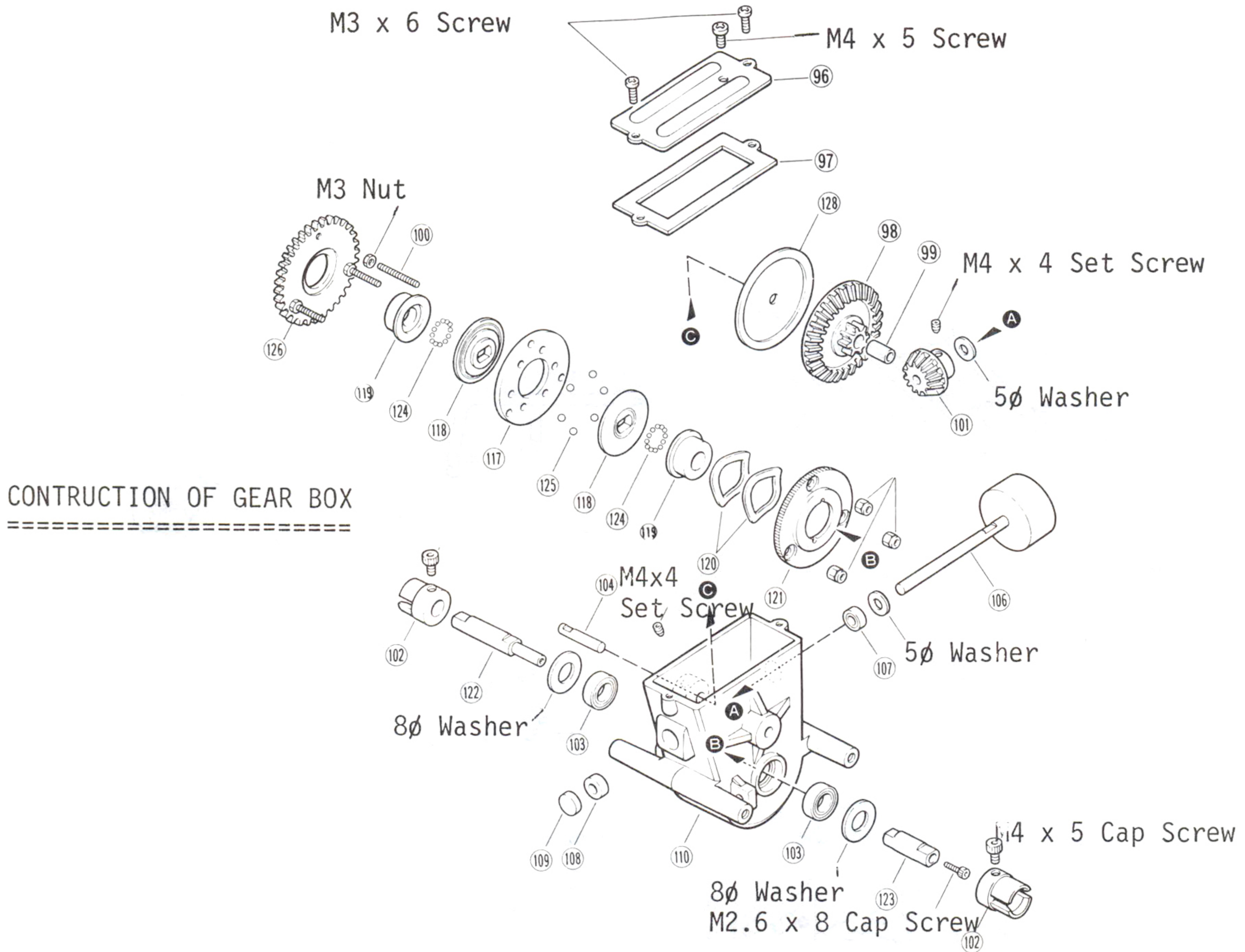

INDIVIDUAL PARTS LIST

Key No.	Parts Name	Qty.	Key No.	Parts Name	Qty.
1	Main Frame	2	21	B Washer	2
2	Arm Holder (left . right)	1 set	22	Servo Saver Set	1 set
3	Arm Shaft A	2	23	Servo Saver installation hardware	1
4	Arm Joint	1	24	Steering Rod	1
5	Suspension Stopper	2	25	Keeper	2
6	Arm Shaft B	1	26	Tension Rod	2
7	Front Spring (left . right)	1 set	27	Lining	2
8	8φ Stopper	2	28	Rear Frame	2
9	Front Suspension Arm (L-1, L-2, R-1, R-2)	1 set	29	Rear Suspension Drive	2
10	Suspension Side Stopper	4	30	Engine Mount (right)	1
11	Upright	2	31	" (left)	1
12	Ball Seat	4	32	Rear Pin	2
13	Front Wheel Shaft	2	33	Rear Sus. Holder	2
14	Knuckle Arm	2	34	Rear Sus. Plate	2
15	E Ring (E-7)	4	35	Stutted Bolt	1
16	Tie Rod	2	36	Rear Pin Joint	1
17	Tap A	1	37	Brake Shoe	1
18	Tap B	1	38	Brake Rod	1
19	Tie Rod Stopper	2	39	Brake Adjuster	1
20	Front Bumper	1	40	L Crank	1 set

<u>Key No.</u>	<u>Parts Name</u>	<u>Qty.</u>	<u>Key No.</u>	<u>Parts Name</u>	<u>Qty.</u>
41	Joint Collar	2	96	Gear Box Cover	1
42	Spring Guide	2	97	" Seal	1
43	Spring Guide Ecn	2	98	Bevel Gear (L)	1
44	3ø Stopper	4	99	Bevel Gear Bush	1
45	Roll Bar	1	100	Stud Shaft	3
46	Rear Suspension Arm (Left . Right)	1 set	101	Bevel Gear (S)	1
47	Rear Suspension Shaft	2	102	Joint	2
48	Rear Wheel Shaft	2	103	8ø Bearing	2
49	Rear Wheel Shaft Bearing	2	104	Bevel Gear Shaft	1
50	Swing Shaft	2	105	Rear Guard (Racing Baja)	1
51	Rear Spring	2	106	Clutch Bell (w/shaft)	1
52	Tension Rod Holder	2	107	5ø Bearing	1
53	Nylon Washer	4	108	5ø Oilless Metal	1
54	Rear Sus. Plate Collar	4	109	Bear Box Metal Cover	1
55	Rear Frame Joint	1	110	Gear Box	1
56	E Ring (E - 3)	2	111	Mechanism Box Cap	2
57	Gear Box Guard	1	112	Body Guard Hook	1
58	Flywheel	1	113	Forked Pin	1
59	Clutch Pin	2	114	Mechanism Box Seal	1
60	Pilon Nut (inch)	1	115	Fly Wheel Shim	1
61	" (mm)	1	116	Mechanism Box Cover Cap	1
62	Clutch Shoe	2	117	Center Plate	1
63	" Spring	2	118	Ball Holder	2
64	" E Ring	1	119	Flange	2
65	Front Tire	2	120	Wave Washer	2
66	Rear Tire	2	121	Thrust Plate	1
67	Front Wheel	2	122	Center Shaft (A)	1
68	Rear Wheel	2	123	Center Shaft (B)	1
69	Front Wheel Metal	4	124	Ball (S)	28
70	Drive Washer	2	125	Ball (L)	6
71	Wave Washer	4	126	Spur Gear	1
72	Mechanism Box	1	127	Front body hook	1
73	Switch Rubber Boots	1	128	Bevel Plate	1
74	Rod Rubber Boots	2	129	Driver Guard(Racing Baja)	1
75	Battery Holder Hardware	2			
76	Servo Bracket	4			
77	Steering Rod	1			
78	Linkage Rod	2			
79	Linkage Stopper	2			
80	Brake Linkage Rod	1			
81	Throttle Control Rod	1			
82	Nylon Collar	1			
83	Throttle Control Stopper A	1			
84	Throttle Control Stopper B	1			
85	Rubber Band	2			
86	Antenna Guide	1			
87	Tank Holder Hardware	1			
88	Tank Set	1 set			
89	Air Filter Set	1 set			
90	Switch Plate	1			
91	(not used)				
92	Mechanism Box Cover	1			
93	Body (Racing Baja)	1			
94	Mission Oil	1			
95	Seal	1			

KIT NO.3045 CIRCUIT 20 EXTRA "RACING BAJA" -PARTS LIST-

PART NO.	PART NAME	KEY NO. & CONTENTS
CB- 3	8ø Stopper	8 x 2
4	Front Spring	7 x 1 set
91	Front Suspension Arm	9 L-1, L-2, R-1, R-2 x 1
7	Tap Set	17, 18 x 1
SD- 42	Keeper	25 x 2
CB- 8	Stud Bolt	35 x 2
12	Spring Set	42, 43, 44, 51 x 2
17	Rear Suspension Holder	33 x 2
72	E-Ring (E - 3)	56 x 5
13	Rear Wheel Shaft	48 x 2
92	Rear Suspension Arm	46 x 2
15	Rear Suspension Bearing	49 x 2
16	Break Set	37, 38, 39, 27 x 1
26	Joint Collar	41 x 1
28	Clutch Parts	59, 62, 63 x 2
31	Front Tire	65 x 2
352X	Rear Tire	66 x 2
CB- 39	Front Wheel Metal	69 x 4
40	Ball Receptacle	12 x 4
41	Up Right	11 x 2
42	Front Wheel Shaft	13 x 2
43	Knuckle Arm	14 x 2
44	E-Ring (E - 7)	15 x 4
45	Gear Box Cover	96 x 1
46	Gear Box Seal	97 x 1
47	Clutch Bell	106 x 1
49	Bevel Bushing	99 x 1
50	Bevel Gear Shaft	104 x 1
135	Gear Box Assembly	Differential Gear assembled
52	Joint	102 x 2
136	Bevel Gear Set for Diff.Gear	98, 101 x 1
60	5ø Metal	108 x 2
59	Pilot Nut	61 x 1 (For Enya engine)
70	Pilot Nut	60 x 1 (For O.S. engine)
137	Spur Gear for Diff. Gear	126 x 1
138	Flange	119 x 2
139	Ball Receptacle Set	117 x 1, 118 x 2
84	Bearing for Center Shaft	103 x 2
85	Bearing for Clutch Shaft	107 x 2
87	Servo Saver	22 x 1
140	Wave Washer for Diff. Gear	120 x 10
94	Linkage Set	Linkage Rod - 1 set
67	Clutch Spring	63 x 4
56	Lining	27 x 5
80	Front Wheel	67 x 2 (Rowdy Type)
81	Rear Wheel	68, 70 x 2
63	Fuel Tank	88 x 1 set
108	Arm Axle Set	3 x 2, 6 x 1
MS- 16	Servo Mount	76 x 4
CB-112	Arm Joint Set	4 x 1, 5 x 2
113	Tierod Set	16, 19 x 2
114	Front Bumper	20 x 1
FM- 33	B Washer	21 x 5
CB-115	Servo Saver Mounting Metal	23 x 1
116	Rear Frame	28 x 2
141	Thrust Plate	121 x 1

PART NO.	PART NAME	KEY NO. & CONTENTS
CB-119	Rear Stay	32 x 2, 36 x 1
142	Center Shaft (w/Screw)	122, 123 x 1
143	Ball Set	124 x 28, 125 x 6
SD- 76	Fly Wheel	58 x 1
LD- 44	Wave Washer	71 x 8
CB- 79	Radio Box	72, 92, 114, 116 x 1, 111 x 2
124	Linkage Boots	73, 90 x 1, 74 x 2
110	Air Cleaner	89 x 1 set
144	Stud Shaft	100 x 10
145	Gear Box for Diff. Gear	110 x 1
127	Suspension Side Stopper	10 x 4
146	Rear Suspension Plate	34 x 2, 54 x 4
129	Arm Holder	2 x 1 set
130	Decal	95 x 1
106	Main Frame	1 x 2
CB- 64	Gear Box Guard	57 x 1
147	Roll Bar & Hook	45 x 1, 112 x 1
148	Rear Frame Joint	55 x 1
151	Swing Shaft for Extra	50 x 2
152	Gear Box for Diff. Gear	107,108,109,110 x 1, 103 x 2
153	Tension Rod for Extra	26, 52 X 2
154	Rear Suspension Pivot	47, 29 x 2
159	Screws Set	Screws, Nuts & Washers for entire car
149	Driver Guard(Racing Baja)	129 x 1
150	Rear Guard (Racing Baja)	105 x 1
155	Lexan Body (Racing Baja)	93 x 1
162	Front Body Hook (Racing Baja)	127 x 1
OPTIONAL PARTS		
CB- 29	Aluminum Front Wheel	Die-cast
30	Aluminum Rear Wheel	Die-Cast
SD- 23	Heatsink for Enya .19 BB	Die-Cast
75	Heatsink for Enya .19 .21X	Die-cast
CB- 36	Super Spike	Rubber
88	Front Oil Damper	With mounting Metal
89	Rear Oil Damper	" " "
95	Rear Wheel Double Bearing	
102	Magnesium Front Wheel	
103	Magnesium Rear Wheel	
104	Circuit Muffler	For O.S. .21 & Enya .21 (Common use)
101	Front Wheel Bearing	
FM- 59	M6 Nylon Nut	
CB- 86	Nylon Super Spike	Hard Plastic
75	Front Wheel	67 x 2
76	Rear Wheel	68, 70 x 2
DEC-03	Number Sticker	
CB- 126	Body Rowdy Baja (Roll Cage)	
CB- 127	Body Mounting Metal (Rowdy Baja)	
CB- 125	Drive Doll Rowdy Baja	
CB-166	Front Wheels Pair (2pcs type) for Sand Super Tires	
CB-167	Rear Wheels Pair (2pcs type) for Sand Super Tires	

KYOSHO CORPORATION